

When using either a GRS Positioning Vise or Turntable under a microscope, the user soon realizes that precise alignment of the microscope's center of view with the rotational center of the vise or turntable is quite important. While the user can do this with medium accuracy fairly quickly, precision alignment for higher magnification work can get tricky. The GRS Target System for microscopes is designed to help the user maintain an area of work within the field of view of the microscope.

INSTALLATION FOR A NEW VISE OR TURNTABLE:

To use the target system, simply mount the base block to the turntable (fig. 1) or positioning vise (fig. 2) and slide the post into the base block. There are two positions, one to locate center and the other to hold the target away from the working area. The target system comes with two adjustments, one for vertical rotational movement on the vertical post and the other for horizontal adjustment. By loosening the adjustment screws, the user can set height above the work piece along with locating the target above the center of rotation. Make sure that the vertical post has been rotated counter clockwise to the stop before setting the center position. This will allow one to swing the target out while working and allow one to bring it back to center when needed.

INSTALLATION FOR AN EXISTING VISE / TURNTABLE:

Your turntable or positioning vise may not have the appropriate holes predrilled for the base block. The templates provided can be used for correct placement of the holes. Once complete, the target system is ready to be mounted.

After setting the target center, the user can swing it to the other stop or pull the target from the base block while they work.

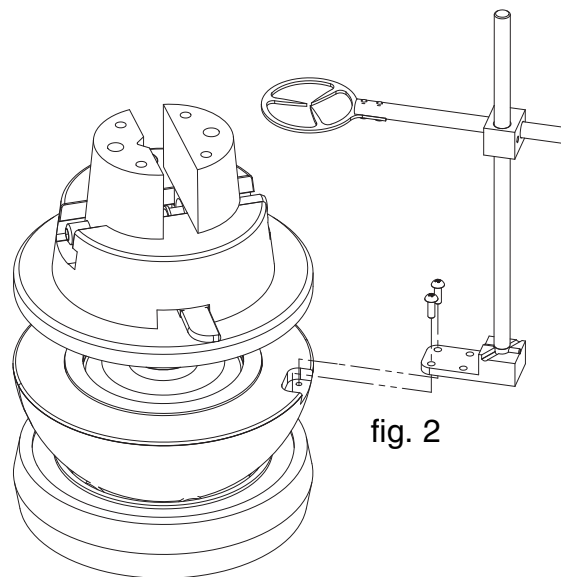
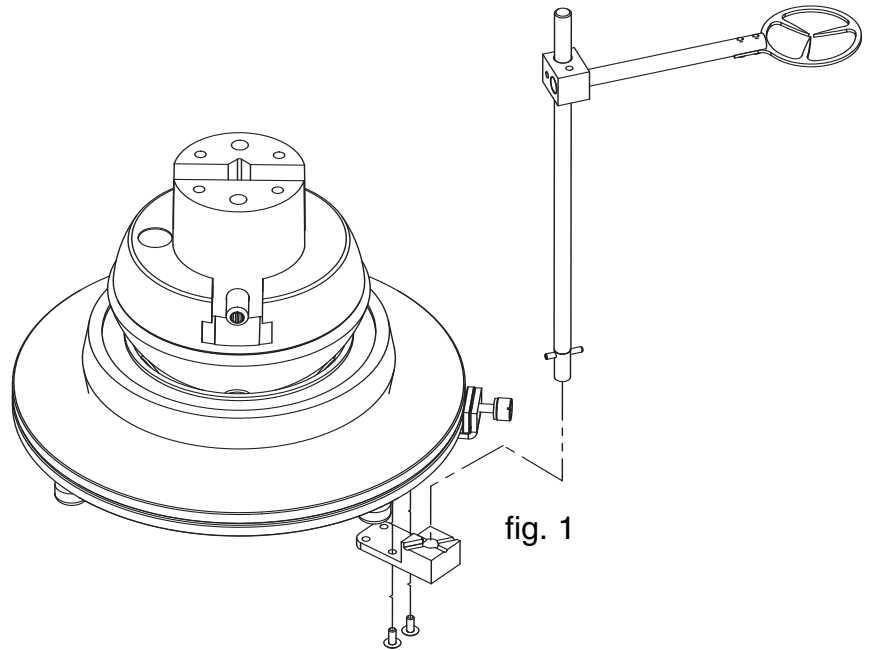

OPTIONS FOR MODIFICATION OF AN EXISTING VISE OR TURNTABLE:

1) Modify the parts yourself using the templates provided. Refer to maintenance instructions on our website, www.grstools.com, for disassembly procedures of the turntable or positioning vise.

2) Take your turntable or positioning vise to a local machine shop along with these instructions.

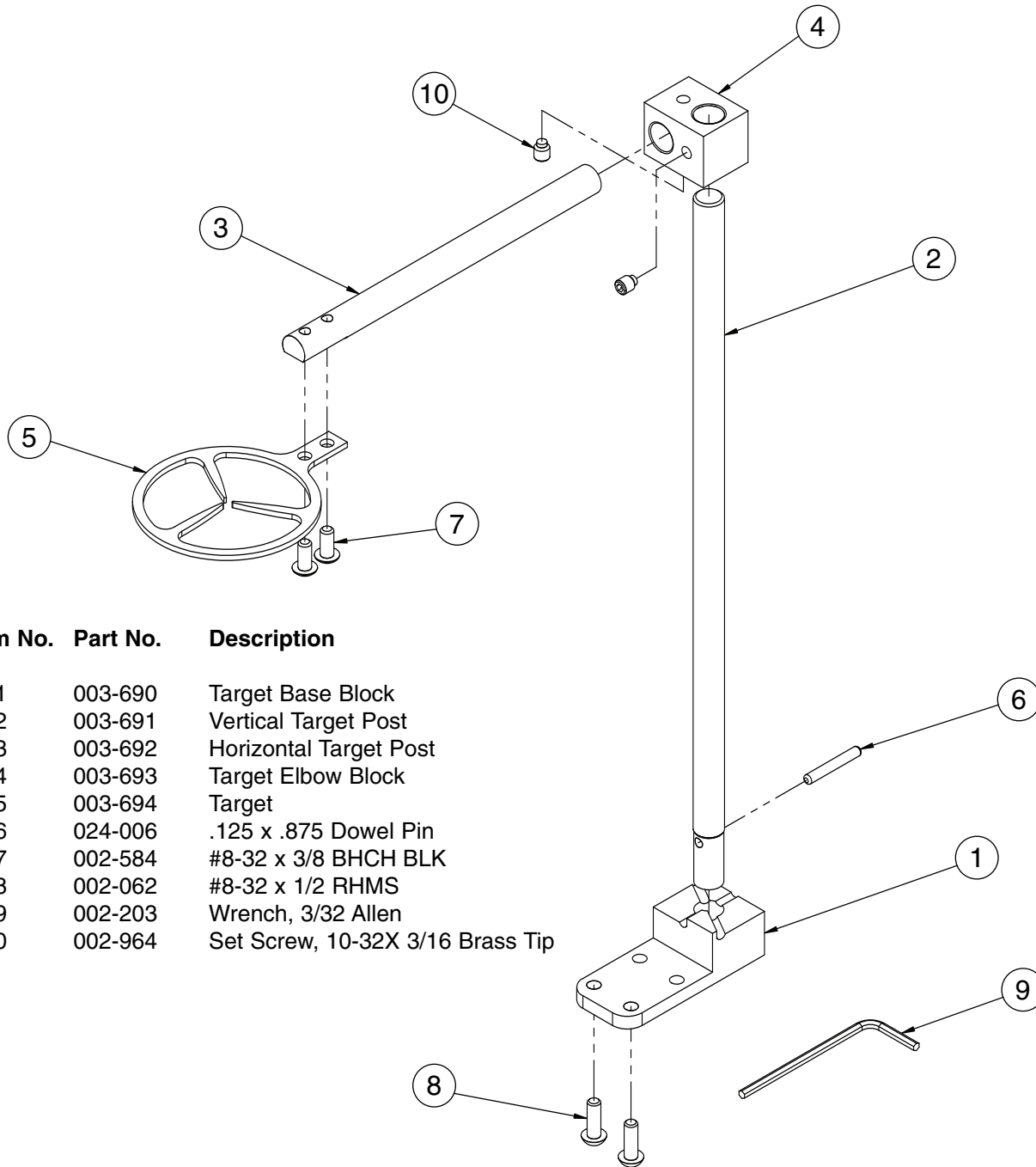

Item No.	Part No.	Description
1	003-690	Target Base Block
2	003-691	Vertical Target Post
3	003-692	Horizontal Target Post
4	003-693	Target Elbow Block
5	003-694	Target
6	024-006	.125 x .875 Dowel Pin
7	002-584	#8-32 x 3/8 BHCH BLK
8	002-062	#8-32 x 1/2 RHMS
9	002-203	Wrench, 3/32 Allen
10	002-964	Set Screw, 10-32X 3/16 Brass Tip

GLENDO
CORPORATION

900 Overlander Road
P.O. Box 1153
Emporia, KS 66801 USA
800-835-3519 • 620-343-1084
fax 620-343-9640
glendo@glendo.com
www.glendo.com

Template for existing turntable.
Template actual size.

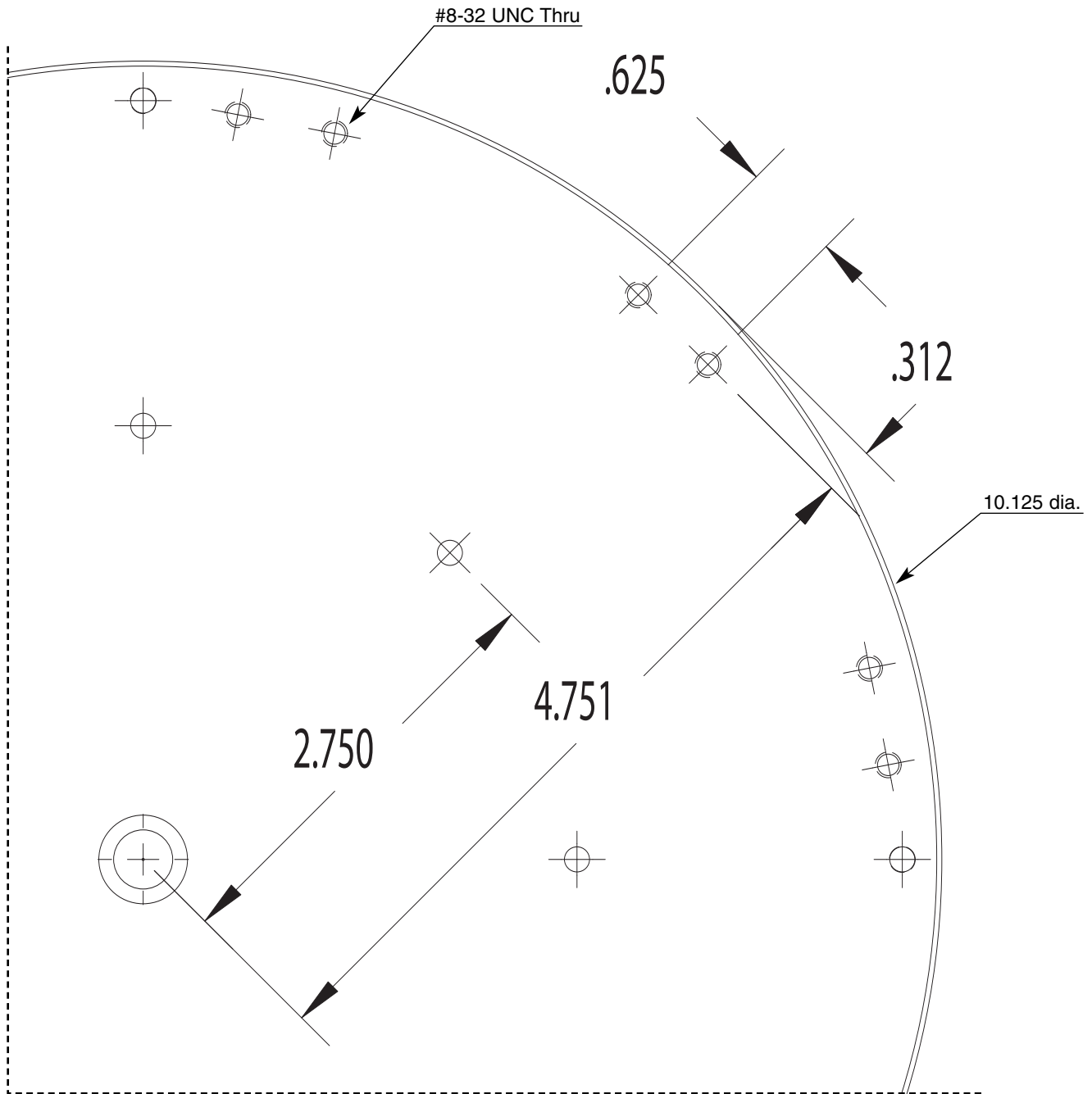

Template for existing Positioning Vise.

