

GRS/Meiji Working Microscope

Focusing

The main point is to adjust your microscope so it stays sharply in focus for both eyes throughout the entire zoom range. There is a lot more to this than just turning the focus knob, so please read this carefully. Follow these steps accurately and in order. Additionally, you should also read the microscope Owner's Manual.

If you wear eyeglasses, you can work without them because your microscope has individual diopter adjustments for each eye. If you wish to wear glasses, we recommend purchasing the Eyeglass Rubber Pad Eyepieces (#003-648) to prevent scratching your lenses, especially plastic lenses.

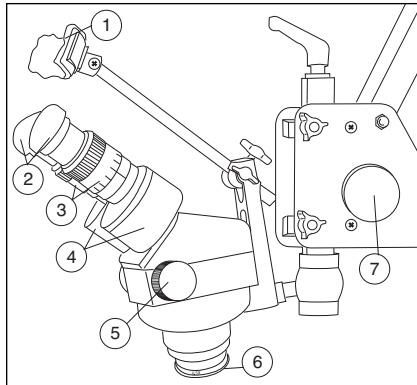

1. Headrest
2. Removable Eye Cups
3. Eyepiece Focus
4. Eye Tube Adjusters
5. Zoom Knob
6. Interchangeable Auxiliary Lens
7. Focus

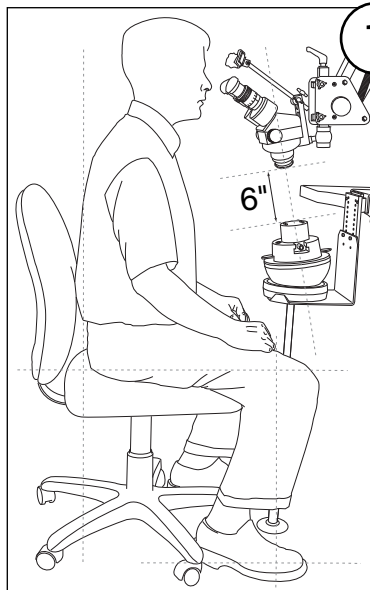

1 Before using your GRS/Meiji Microscope you must first position yourself and equipment properly. Start by sitting in a comfortable chair with both feet planted on the floor, and back straight. Next, adjust the ball vise and microscope with the bottom of the microscope parallel to the top surface of the ball vise, leaving about 6 inches of working space (see illustration at left). Adjusting the equipment correctly will help you maintain good posture. Now you are ready to make the necessary focusing adjustments to the microscope for use.

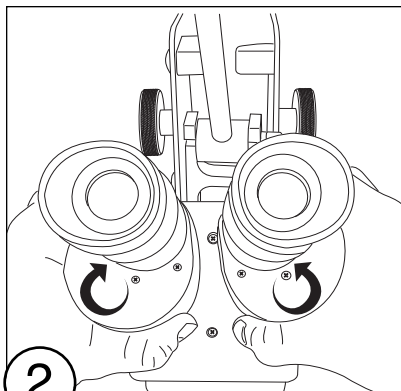

2 While looking through the eyepiece lenses, move the eyepiece tubes further apart or closer together until they match the distance between your eyes. When you see one central image, the distance is correct.

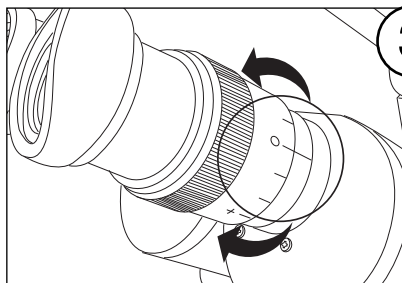
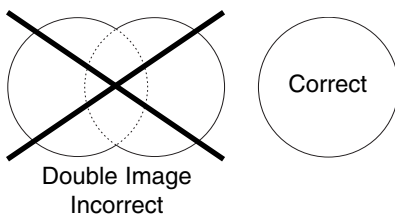

3 Rotate each eyepiece tube until the '0' mark aligns with the scribed mark below it. This sets both eyepieces to a neutral (0) diopter.

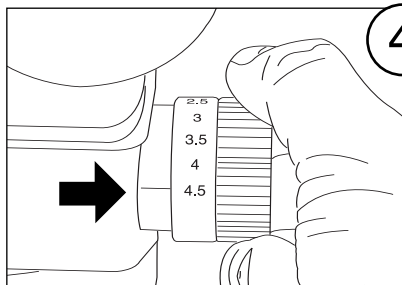

4 Turn zoom knob clockwise to 4.5, the highest power setting.

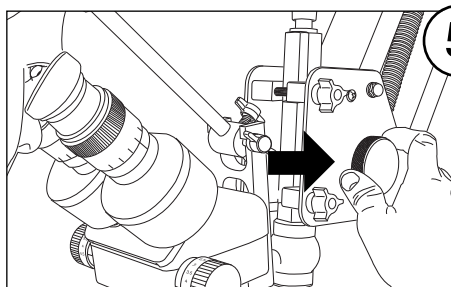

5 Look through the microscope, and focus on a simple object placed on the ball vise.

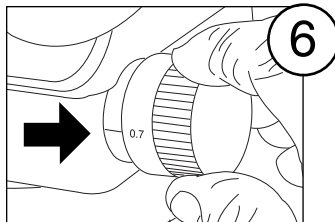

6 Zoom to the lowest power 0.7. DO NOT refocus! If it lacks clarity at the lowest power, you will need to adjust the diopter for each eye.

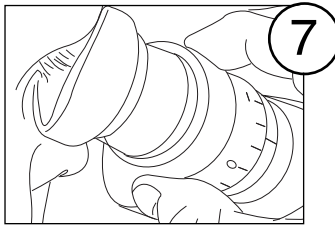

7 After focusing and the image is still blurry, look with only your right eye, rotate ONLY the right eyepiece tube to adjust the diopter until the image is perfectly clear. DO NOT change any other settings while doing this. Repeat your left eye and left eyepiece tube.

After completing these seven steps...

the image should now be uniformly sharp with both eyes. If you've done these steps accurately, it will stay in focus throughout the entire zoom range WITHOUT refocusing. Remember that focusing at high magnification is more accurate, but has less depth of focus than low magnification. Although, you bought a microscope to see "up close," you may tend to use excessive magnification at first. Working at higher magnification than necessary can sometimes make your work slower and more awkward. At lower magnification, the area you see is greater and the focus is more forgiving.

Working Distance

The working distance is the distance from the bottom of the microscope to the viewing surface when properly focused. The ONLY thing that changes the working distance of your microscope is the auxiliary lens that screws onto the

bottom of the microscope. The chart below shows the optical specifications for the GRS/Meiji Microscope for a variety of auxiliary lenses. (*Note: Sometimes the auxiliary lens is also called a supplementary lens.*)

Auxiliary (Supplementary) Lens	Magnification (Zoom) Range*	Field of View Diameter* in. (mm)	Working Distance in. (mm)
0.30X #003-591	2.10 to 13.50X	4.29" - 0.67" (109 - 17mm)	9.25" (235mm)
0.44X	3.08 to 19.80X	2.93" - 0.45" (74.5 - 11.5mm)	7.13" (181mm)
0.50X #003-567	3.50 to 22.50X	2.58" - 0.40" (65.6 - 10.2mm)	5.91" (150mm)
0.75X	5.25 to 33.75X	1.72" - 0.27" (43.7 - 6.8mm)	3.82" (97mm)
Without Lens (1.00X)	7.00 to 45.00X	1.29" - 0.20" (32.8 - 5.1mm)	3.66" (93mm)
1.50X	10.5 to 67.50X	0.86" - 0.13" (21.8 - 3.4mm)	1.93" (49mm)
2.00X	14.0 to 90.00X	0.65" - 0.10" (16.4 - 2.6mm)	1.34" (34mm)

* This Magnification Range and Field of View is for 10X eyepieces only. If you use other eyepieces, it will change accordingly. Eyepieces available from 10X to 30X.

Magnification

The total magnification is the multiplication of all lenses. There are three numbers involved: eyepiece power, zoom power of the body, and auxiliary lens power. Example: For a microscope with 10X eyepieces and a 0.5 auxiliary (supplemental) lens, if you zoom to a value of 2.5 (as seen on the zoom knob scale, the overall magnification is $10 \times 0.5 \times 2.5 = 12.5$ power. Other magnifications can be calculated the same way. Remember, if you want to change the overall magnification without changing the working distance, you must either change the zoom knob setting or the eyepieces. Changing the auxiliary lens will ALWAYS change the working distance! Eyepieces for the GRS/Meiji Scope are available in 10X, 12.5X, 15X, 20X and 30X.

Field of View

This is the working diameter you can see through the microscope. This viewing diameter is dependent on magnification... the higher the magnification, the smaller the diameter of view. The chart above shows a range of values. The biggest field diameter is for the lowest zoom setting, the smallest field for the highest zoom.

Tips

- Keep a dust cover over your microscope when not in use. If dust appears, clean with a soft cloth or eyeglass wipes.

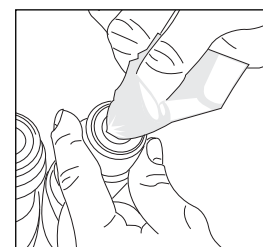
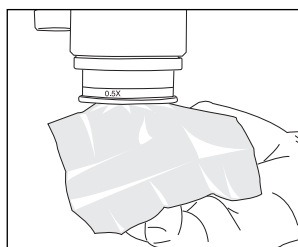

- Spend time to master the correct adjustment of focus and eyepiece settings previously described. You will have less eye strain and faster focusing.
- Remember any optical device that "enlarges" what you see also reduces the amount of light. So, you will need a good light source.

ORDER FORM

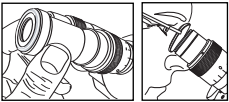
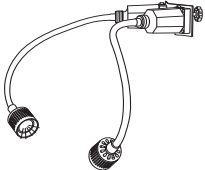
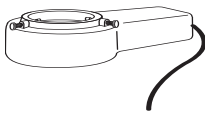
QTY.	PART NO.	DESCRIPTION	COST EACH	AMOUNT
	003-648	 Eyeglass Rubber Pad Eyepiece <i>When working with your eyeglasses on, rest your glasses on top of the pads without scratching the lenses.</i>	\$199.50	
	022-105 022-106	Eyepieces 15X 20X <i>(Suggestion: To see what this eyepiece would be like, remove auxiliary lens, if applicable, and shrink working space to 3 inches and focus. This is very similar to 20X optics.</i>	\$140 (pair) \$146 (pair)	
	003-597 003-596	 Twin Halogen Lights <i>Assembly attaches to vertical post of all GRS microscope stands.</i> 115 Volt 230 Volt	\$348 \$348	
	022-268T 022-268T-220 022-338	 Microscope Ring Light <i>Extra bright circular fluorescent bulb gives cool, glare-free illumination. Fits GRS/Meiji microscopes and many others.</i> 115 Volt Light 230 Volt Light Replace 7000 hour ring bulb	\$179 \$179 \$39.40	
	003-591 -- -- -- --	Auxiliary (Supplementary) Lenses <i>A variety of lenses that allows you to change the magnification and working distance.</i> 0.30X Lens 0.44X Lens <i>(Call for pricing and availability)</i> 0.75X Lens <i>(Call for pricing and availability)</i> 1.50X Lens <i>(Call for pricing and availability)</i> 2.00X Lens <i>(Call for pricing and availability)</i>	\$138 -- -- -- --	



Subtotal: _____

Add appropriate sales tax for Kansas & California

Prices subject to change without notice. TOTAL DUE: _____

Ship To: Company _____
 Name _____
 Shipping Address _____
 City _____ State _____ Zip _____
 Phone _____

Shipping: Enclose money order or personal check and receive free ground shipping in lower 48 states. Freight and handling costs will be charged to credit card orders.

Sent US Mail or UPS ground unless otherwise requested. *Please send via:*

METHOD OF PAYMENT:

- Check or Money Order (For personal check allow 7 days to process)
- Charge my account (listed firms only)
- Mastercard Visa
- American Express Discover

Card No. _____ Exp. _____/_____/_____

MAIL ORDER TO:

Glendo Corporation
 P.O. Box 1153
 Emporia, KS 66801

FAX ORDER TO: 620-343-9640

ORDER TOLL FREE:

1-800-835-3519

Monday-Friday 8am-5pm Central Time
 PLEASE ASK FOR ORDER DESK

 Your Signature