

TOOLS REQUIRED

7/16" & 9/16" wrench or sockets and a large straight slot screwdriver. (Hex wrench is included)

Start assembly by attaching bracket arm (2) to the post collar (1) using the four bolts (8) and washers (11).

Insert the flat head bolt (6) into the countersunk hole in the center of the shelf. While holding the bolt in the shelf, turn it over and place the friction washer (3) over the bolt. Turn the bracket arm (2) upside down and insert the bolt through the hole in the bracket arm that gives the desired shelf position. (NOTE: See placement of shelf below.) Now, insert the thrust bearing (4) over the bolt. IMPORTANT - This bearing MUST be positioned correctly - SEE details at right. Place washer (10) and nut (7) next. Tighten nut firmly.

BELOW ACROBAT ARM SHELF PLACEMENT

Remove Acrobat arm from the post. Place stop collar (12) onto post followed by the shelf assembly. Tighten the stop collar set screw to the post in the desired position. Replace the Acrobat arm.

ABOVE ARM SHELF PLACEMENT

Place stop collar (12) onto post followed by the shelf assembly. Tighten the stop collar set screw to the post in the desired position. Insert knob (9) into the threaded hole in the post collar (1) and tighten to hold shelf in a stationary position OR leave loose to be able to swing shelf out of the way.

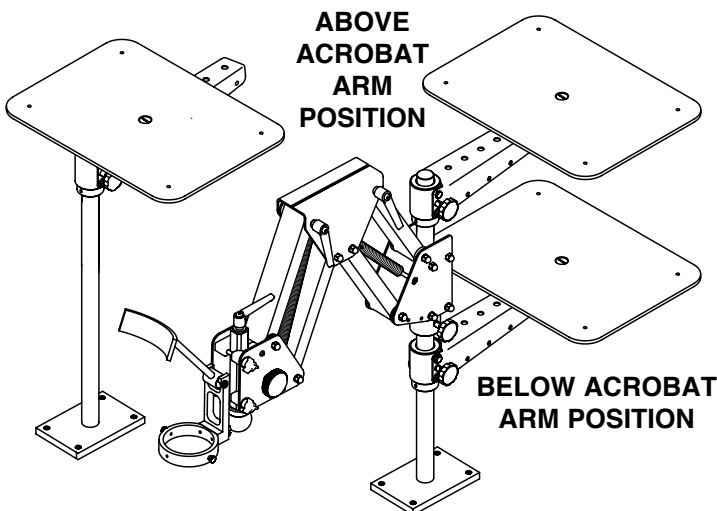

Shelf placement over the post is recommended to hold heavy items such as television or monitor.

IMPORTANT: The thrust bearing must be positioned correctly to keep shelf from becoming loose. Make sure the thrust bearing "HOUSING" is against the bracket and the nut/washer is against open part of bearing.

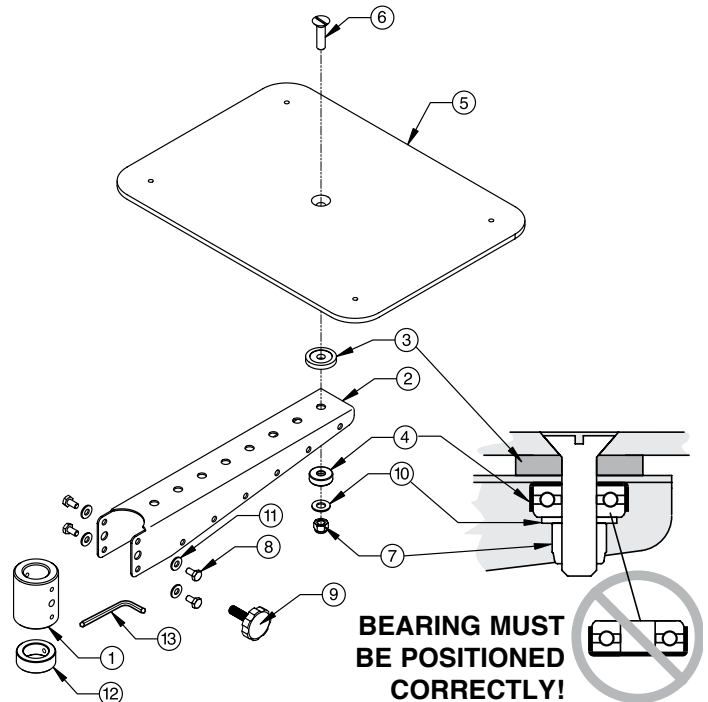

- 1 #003-296 Post Collar
- 2 #003-297 Shelf Bracket
- 3 #004-089 Friction Washer
- 4 #002-510 Thrust Bearing
- 5 #003-298 Shelf
- 6 #022-910 Flat Head Bolt
- 7 #022-911 Hex Lock Nut
- 8 #002-288 Hex Head Bolt (4)
- 9 #004-544 Knob Assembly
- 10 #002-447 Washer
- 11 #022-220 Washer (4)
- 12 #022-912 Stop Collar
- 13 #002-429 Hex Wrench

GLENDO

CORPORATION

900 Overlander Road
P.O. Box 1153
Emporia, KS 66801 USA
800-835-3519 • 620-343-1084
Fax: 620-343-9640
E-mail: glendo@glendo.com
www.grstools.com