

TURNTABLE BASE #003-616-V2 for MICROSCOPE WORK

First, place the centering post in the center of the turntable and position both under the microscope as shown at right. **Note:** The post is the same height as the GRS low profile ball vise. Locate the top of the post while looking through the microscope. Rotating the turntable, position the exact center of the post in the center of view. The turntable is now properly centered. Remove the post, do not move the turntable.

Place the low profile ball vise on the turntable. Tighten the swivel tension screw on the ball vise until the ball will not turn. The turntable now becomes your rotation. Position the ball vise under the microscope with the work area in view. Change working views by moving the block on the turntable, not by moving the turntable.

MAINTENANCE - DO NOT OIL

Occasionally you may want use air and blow any dirt and metal pieces from between the plates.

Swivel
Tension
Screw

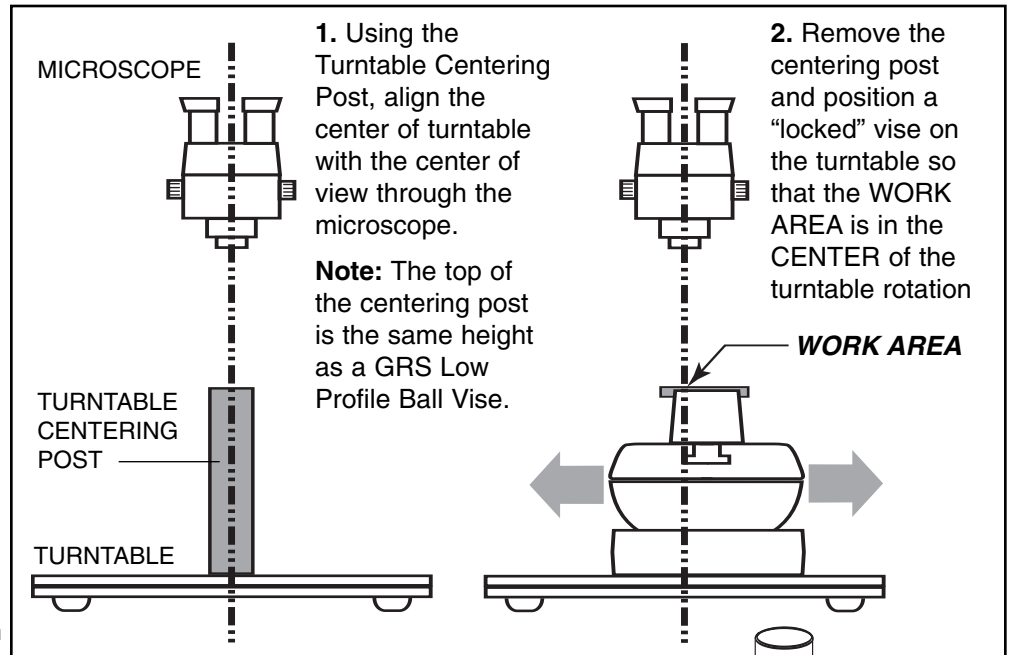
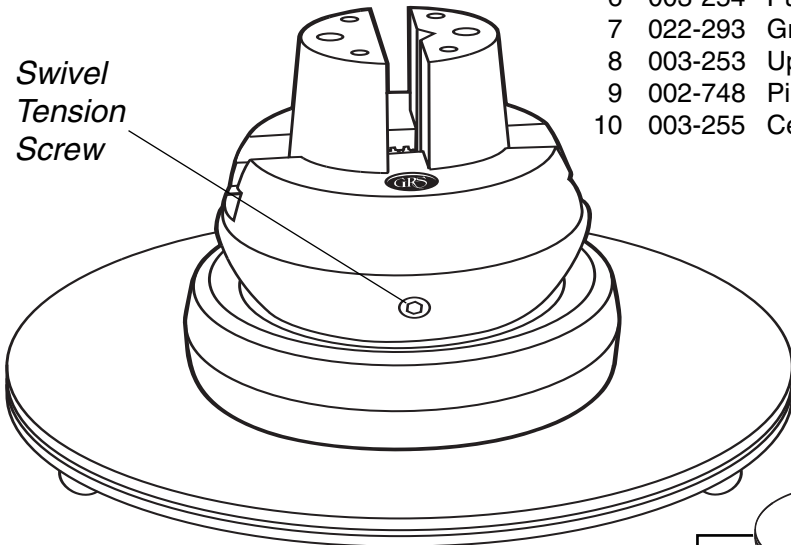

003-616-V2 Turtable Base / Center Post

- 003-639 Turtable Base Assembly
- 003-638 Center Post Assembly

- 1 003-252 Base Plate
- 2 002-036 Rubber Mounting Foot
- 3 022-323 Bronze Flange Bushing
- 4 002-061 #8-32 X 3/8 RHMS
- 5 022-324 7/32" Delrin Grade 1 Ball
- 6 003-254 Pull Out Dowel Pin
- 7 022-293 Grip Ring
- 8 003-253 Upper Plate
- 9 002-748 Pin
- 10 003-255 Center Post

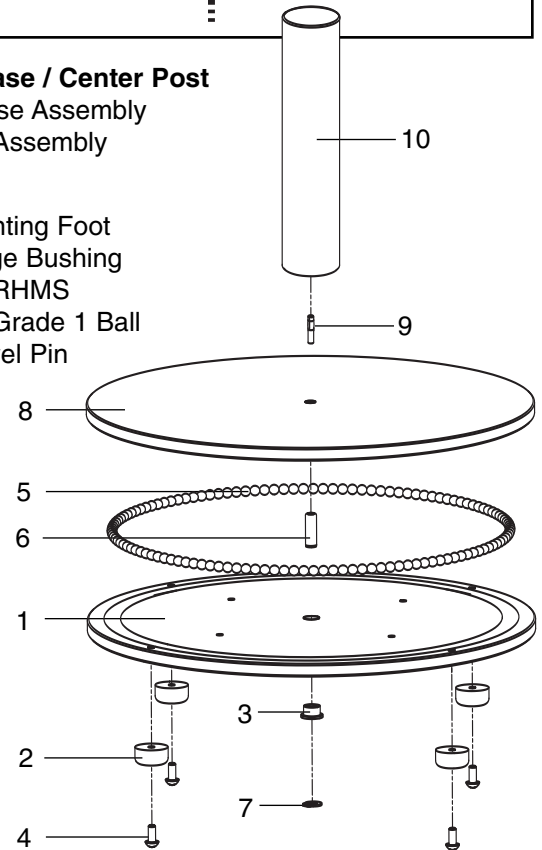

GRS Tools

900 Overlander Road
Emporia, KS 66801 USA

Fax: 620-343-9640
Tel: 620-343-1084
e-mail: GRS@GrsTools.com
www.GrsTools.com

LIT#157

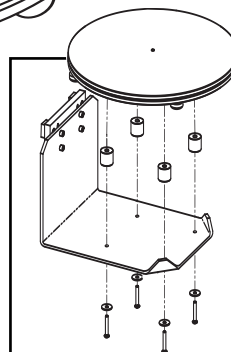

TURNTABLE MOUNT KIT

Part #004-672 is required to mount the turntable on GRS Large Block Shelf #004-665.

NOTE: TURNTABLE WILL NOT MOUNT ON STANDARD BLOCK SHELF #004-578