

GRS 901 Handpiece INSTRUCTIONS

For GraverMach & GraverMax SC

#004-901

	Standard Spring	Fine Spring
Normal Operating Range	18-22 psi (1.2-1.5 bar) / 1400 - 3400 spm	12-15 psi (0.8-1.0 bar) / 1600 - 3600 spm
Recommended Initial Setting	19 psi (1.3 bar) / 2700 spm	13 psi (0.9 bar) / 3000 spm
PSI: Pounds per Square Inch • Bar: Unit of Measurement • SPM: Strokes Per Minute		

Adjusting The Handpiece To Fit You

With the locking ring slightly loose, you are able to turn the handpiece body and knob independently. Position the Quick Change holder with the graver "point" down. Rotate the knob until the hose position is comfortable, then tighten the locking ring.

You can also extend the length of the handpiece a little by unscrewing the knob and body even more. **NOTE:** By extending the length you may notice a loss of power depending on the type of work you are doing.

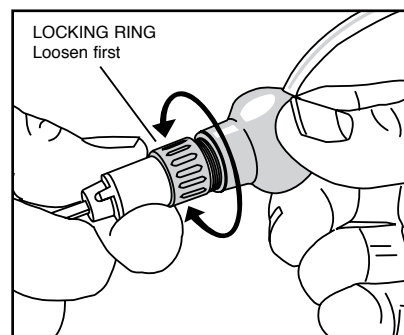

How To Attach A New Hose

Loosen the locking ring. Remove the knob from the handpiece. Remove the hose by cutting it off close to the knob. With a small punch, push the hose / brass fitting back into the knob body. Remove the brass fitting (#004-409) from the hose. Feed the new air hose through the hole in the knob (Fig. 1). Insert the brass fitting into the end of the new hose, making sure it is fully seated.

If needed, lubricate the fitting first to help it slip into the hose easier. Then apply a small amount of water or oil around the outside end of the hose next to the brass fitting and pull the hose back (Fig. 2) into the knob until you see the tip of the brass fitting protrude through the side of the knob. This must be an air tight fit, so you will have to pull somewhat hard (a few pounds of pressure, at least).

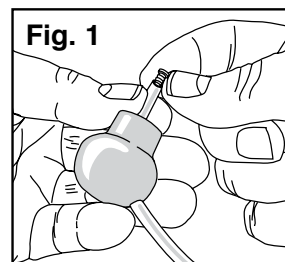

Lubricate end slightly with water or a small amount of oil.

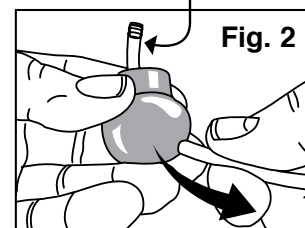

Create A Flat On The Bottom (If Desired)

If you choose to put a flat on the knob, use the handpiece first to find out where the hose "exit" is most comfortable for you. *Note warranty information to the right.*

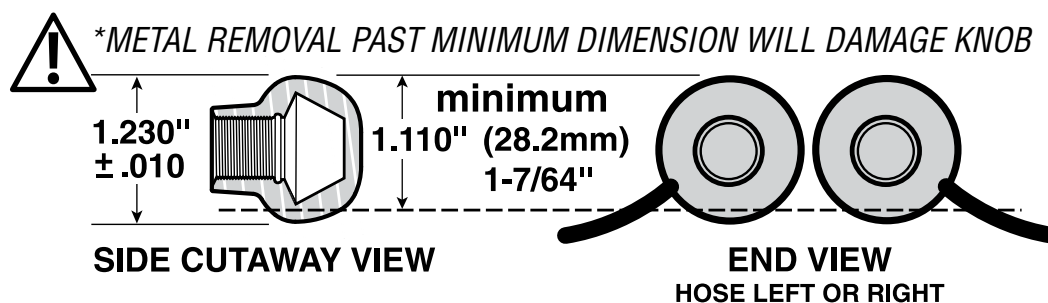

IMPORTANT

Too much material removal will result in damaged* knob (PART #004-404).

*Any damage to knob from creating a flat is NOT covered by warranty.

Maintenance

Keeping the 901 clean on the inside. Problems will occur if oil or moisture gets into the handpiece, especially on the piston. If you notice a loss of power or erratic performance, first check if the **receiver (chuck) is tight in the handpiece body**. Using a crescent wrench or pliers with a graver inserted in the QC Holder, gently tighten receiver clockwise (Fig. 3) If erratic performance continues, then disassemble and clean the handpiece. To disassemble the handpiece, use the crescent wrench or pliers to grip the graver (Fig. 3) and turn it counterclockwise to loosen the chuck retainer. *Continued on page 2.*

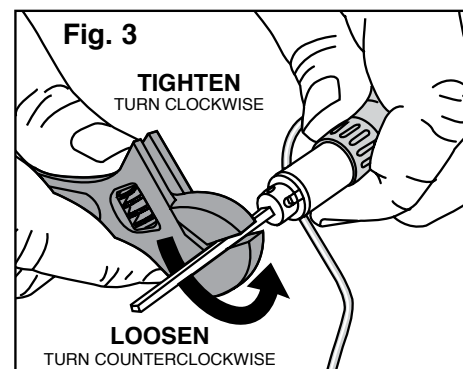

After loosening you can turn the chuck retainer out with you finger tips (Fig. 4). As you pull out the chuck there will be a spring and piston that follows. Loosen the locking ring and remove it (Fig. 5). Grip the knob and turn the handpiece body counterclockwise until it is out of the knob body (Fig. 6).

Now, with the handpiece disassembled, clean the parts with a NON-residue solvent like denatured alcohol. Make sure the holes in the handpiece body are clear from dirt and debris. **DO NOT** get moisture down the air hose. If this happens you will need to clear and dry it before reassembly.

Before reassembly, make sure every thing is completely dry. **DO NOT OIL INSIDE THE HANDPIECE.** NO lubricant is required. Lubricant will actually take away performance!

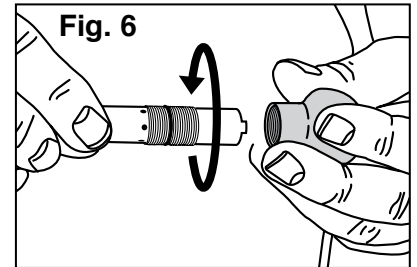
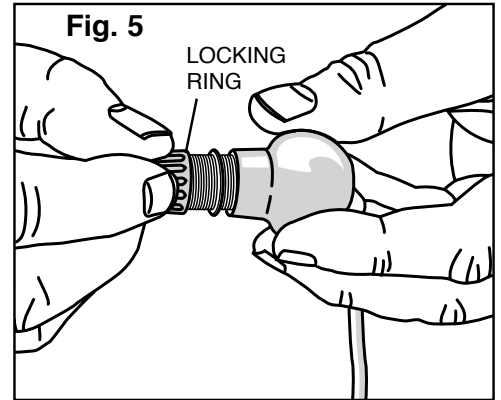
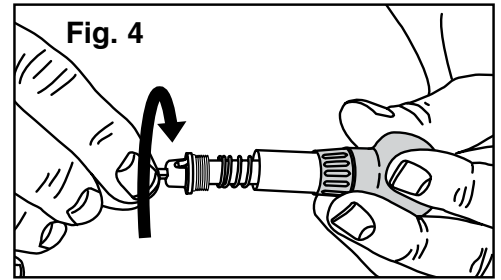

NOTE: Do NOT use petroleum based oils - USE ONLY Synthetic oils. Fossil oils can damage the O-Rings.

Reassembly Note

There is an O-ring inside the knob that makes getting the handpiece body to thread a little difficult when reassembling. Use a very small amount of synthetic lube or Teflon grease and create a thin film around the OUTSIDE of the shaft between the threads and the end (Fig. 7). See "Adjusting The Handpiece To Fit You" on p. 1 of this literature sheet for adjusting graver and hose position.

Quick Change Holder Hint

Synthetic Lube or Teflon Grease on the shaft of a quick change holder will make them easier to slip in and out.

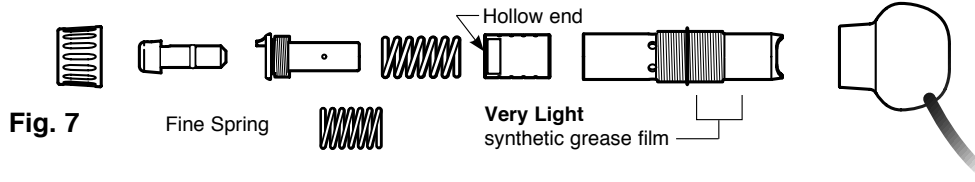

Fine Spring Option

The Fine Spring offers you the option to tune the 901's power for finer engraving work. With this spring in the handpiece, the air pressure will need to be approximately 14 psi.

To Change Springs

Place a Quick Change Holder with a graver in the chuck. Using a wrench or pliers grip the graver (Fig. 8) and turn it counterclockwise to loosen the chuck retainer. After loosening you can turn the chuck retainer out with you finger tips. As you pull out the chuck there will be a spring and piston that follows. Replace the spring with the shorter "FINE WORK" spring and reassemble.

NOTE: The piston has a hollow end. The hollow end **MUST** be next to the spring or it will NOT work properly.

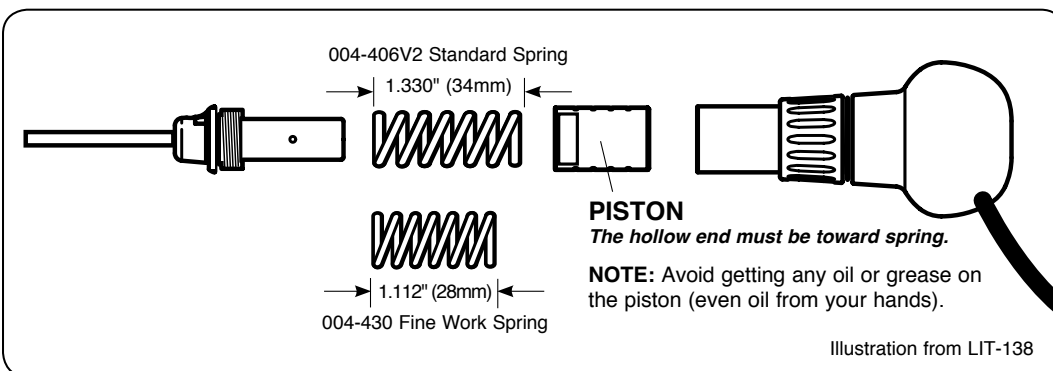
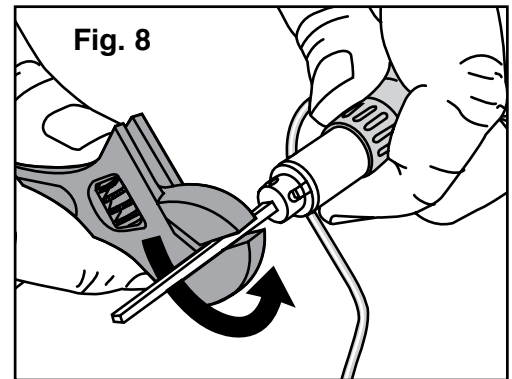

900 Overlander Road
P.O. Box 1153
Emporia, KS 66801 USA
Toll-Free: 1-800-835-3519
Phone: 620-343-1084
Fax: 620-343-9640
E-mail: grs@grstools.com
www.grstools.com