



# Ring Size Cutter INSTALLATION & OPERATION

## READ FIRST

We know you are eager to use your new GRS Ring Size Cutter. But, PLEASE familiarize yourself with proper installation and operating procedures BEFORE you begin. Improper installation and use could damage your new ring cutter or cause personal injury!

*Thank you for buying a GRS product.*

## INSTALLATION

The ring size cutter comes with its handle moved for shipping. You must reinstall the handle in order to use it. First, remove the hex-head bolt and spacer located on the cutter crank pin (Fig. 1). Slide the handle out and rotate the cutter crank pin until you can replace the handle as shown in Fig. 2. Replace the hex-head bolt with spacer into the tapped hole in the handle and tighten.

The ring size cutter must be securely fastened to a workbench or table top. Four metal screws are provided for this purpose. If these screws are not compatible with your bench top, you must supply a fastener with equal or greater strength. The shearing action requires moderate force on the handle. The cutter must be secured to safely absorb this force without pulling itself loose from the workbench. Be certain that the ring cutter is mounted properly to avoid possible injury.

Most users will want to mount the ring cutter near the front of their bench. We suggest that you mount it back far enough to allow for a "catch tray" under the cutter area to collect the ring slugs. You might consider putting the front mounting screws about 6" in from the edge of your bench. (Fig. 3)

## CAUTIONS

Since this tool will cut metals, it will easily cut your finger or most anything else you put under the cutters. You do NOT need to have your fingers near the cutter when actually making a cut. Once you are certain that the ring and cutter are correctly positioned, remove your fingers and smoothly pull the handle.

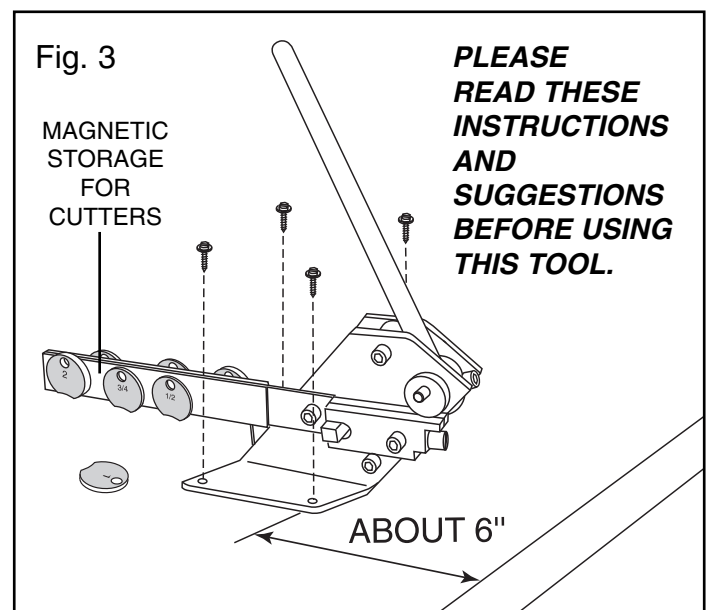
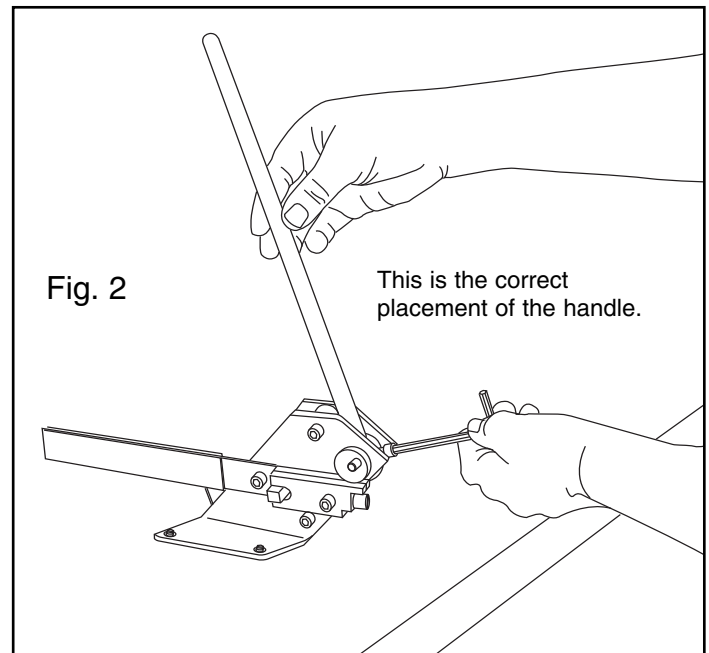
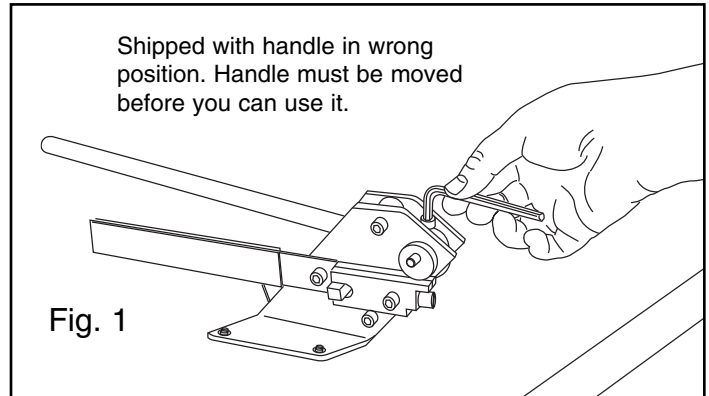

## Read these TIPS to AVOID Frustration and RING DAMAGE.

The GRS Ring Cutter cuts by shearing. Some ring shank shapes and softer alloys may be distorted by this cutting process. Here are some ways to minimize or prevent this:

**1** Observe how the ring shank fits the curved area of the cutter. Some shanks don't fit the cutter curve well enough. In a short time you'll know which rings may cause problems just by looking at them. You may decide not to cut some rings with the Ring Cutter. Most jewelers report using the GRS Ring Cutter well over 80% of the time. Many tell us they use it virtually 100% once they understand it. We want to share this actual trade experience because the more you understand, the more you'll like this wonderful tool.

**2** HERE'S A TIP FROM A LIFETIME BENCH JEWELER: If you think distortion may be a problem, select the ring cutter that is 1/4 size less than the total you need to remove. After cutting with the ring cutter, close the ring shank but don't solder it yet. It should now be 1/4 size bigger than the desired final size. Using a rigid separating disc in your flex shaft or rotary handpiece (the standard disc is .023" (0.6mm) wide), cut the ring shank along the same cut shank again. You should now have a nice parallel joint, free from distortion. Now solder and finish. The ring should be the correct size since the separating disc removed the last 1/4 ring size. Note: You shouldn't need to use this technique often, but it's nice to know.

**3** Here's another tip if the ring must be sawed: If the shank is such that it must be sawed, put it in the ring cutter with the correct cutter size. Then, pull down on the handle just enough to slightly mark (with two slight dents) the ring shank with the cutter. These two "dents" will now help guide your saw blade to cut the precise width you need.

**4** The shearing action of the GRS Ring Cutter works on most ring alloys, especially the harder metals you hate to saw by hand. If you size a lot of soft alloys, your Ring Cutter can be customized by GRS to cut these soft alloys with less distortion (at no charge to you except shipping). But, you may lose some ability to cut smaller rings. Contact GRS Tools if interested.

**5** Always remove the cut piece left between the jaws BEFORE cutting the next ring. This piece stays so it won't fall and get lost, but you have to remove it (just open the jaws by turning the knob) so it doesn't interfere with the jaw spacing on your next cut.

## OPERATION

The ring size cutter is actually a special shearing tool. It works by shearing a selected size of shank material from the bottom of the ring. You control the amount of material removed by selecting the corresponding cutter size. There are seven cutter sizes that come with the USA / British ring cutter: from 1/2 to 2 in 1/4 increments. These sizes directly relate to ring sizes. Thus, if you want to reduce a ring by 1 ring size, choose the size 1 cutter. It's that simple. For the metric version there are nine cutter sizes to choose from.

Once you have chosen the cutter size, you will then need to correctly install the cutter for use. First lower the handle to its full down position. Now,

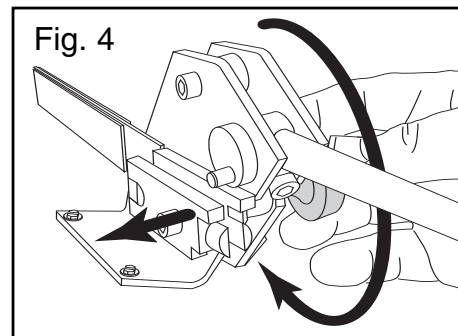

loosen the adjusting knob (Fig. 4) by turning it counter-clockwise. Install your selected cutter by placing its hole over the crank pin and then swinging

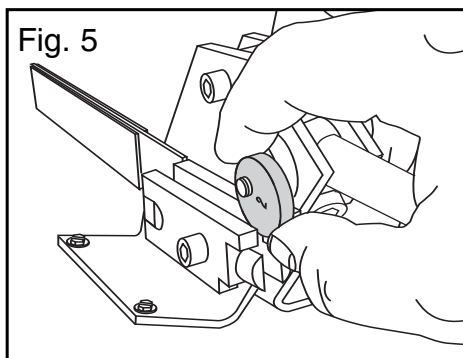

it down between the two cutter bars (Fig.5). If necessary, loosen the adjusting knob further to widen the space between cutter bars.

You are now ready to set the proper clearance for a clean shear cut. Visually verify that the cutter is hanging between the open cutter bars. Now, hold the cutter inward with your finger (Fig. 6) and simultaneously turn the adjusting knob clockwise until a light squeeze is felt between the cutter bars and the cutter. **DO NOT OVER TIGHTEN!** You have now set the correct clearance for your cut.

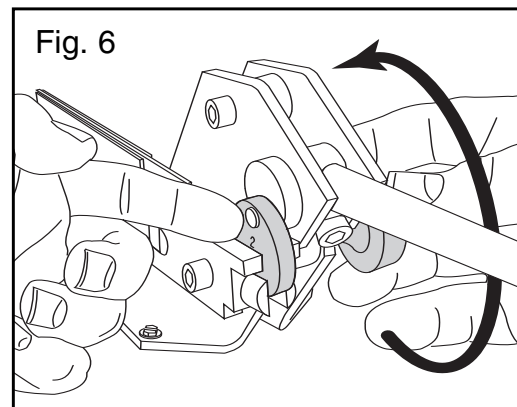

Next raise the handle up fully. Then position your ring over the cutter bars (Fig. 7 & 8). Now lower the handle to bring the cutter in proper contact with the ring. After verifying that the cutter is correctly positioned over the ring

(SEE FIG. 9), pull smoothly downward on the handle until it stops. Your cut is complete. Raise the handle, remove the ring. **BE SURE AND REMOVE THE RING SLUG** from between the cutter bars.

Once you are familiar with cutter selection and adjustment, you will find it to be a fast and simple process. The ring size cutter has specially shaped cutters that conform to most convex ring shanks. Notice that the actual cutting area is a concave notch. This notch must be positioned properly over the ring shank to

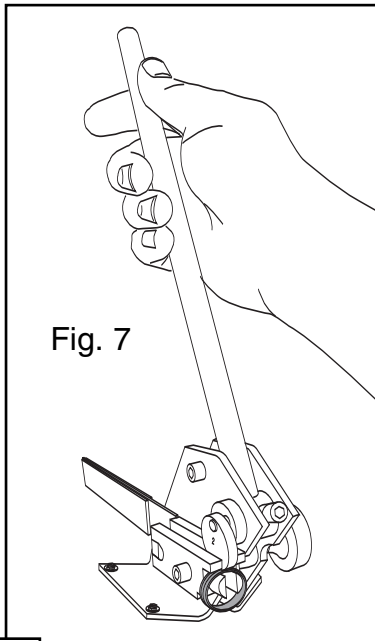

Fig. 7

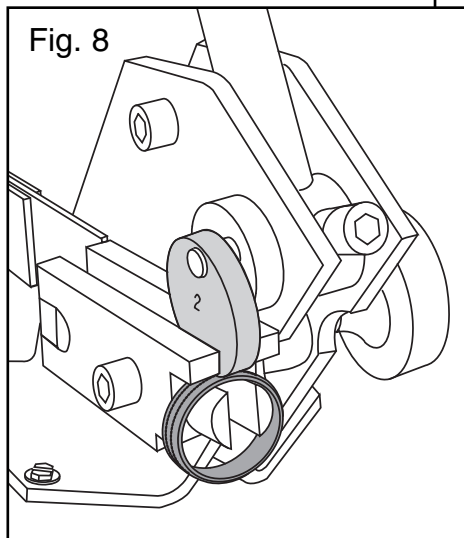

Fig. 8

make a clean cut. Figure 9 shows both the incorrect and correct cutter positions. Although these figures are somewhat exaggerated, they illustrate an important point.

**INCORRECT CUTTER POSITIONS CAN PRODUCE ROUGH CUTS AND DAMAGE THE CUTTERS THEMSELVES!**

## MAINTENANCE

There is very little maintenance required for the ring size cutter. With proper care, the cutters will provide good service. This tool is designed to **CUT PRECIOUS METAL ALLOYS ONLY**, such as used in jewelry. Do **NOT** use it on hard steels, stainless steels, etc. The cutter and cutter bars are replaceable. You will find the complete parts listing on the back of these instructions. Cutters may be ordered individually or in sets.

The cutter crank may need lubricant from time to time. Most oils or grease will work. You may find small amounts of metal building up on the cutters and inside the cutter bars. This build-up can hamper correct cutter clearance since it keeps the cutter bars further apart. If this happens, just remove this built-up metal with a small file being careful not to round the cutting edges. You should **NEVER** attempt to cut anything that does not fit across **BOTH** cutter bars. This tool is designed to cut a notch from a ring or part that is supported on both sides. It is **NOT** a one side shear...using it this way could cause damage.

Fig. 9

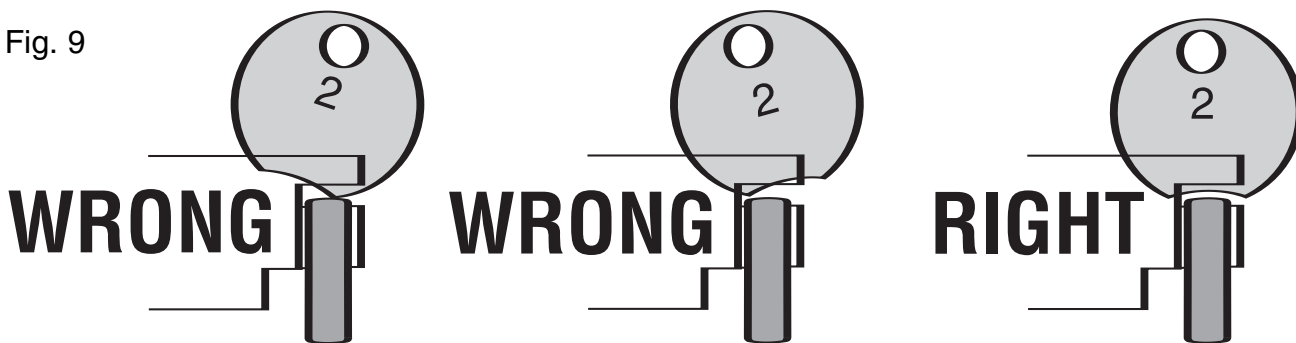

If you follow the correct procedure for adjusting the cutter clearance as outlined in figures 4 to 9, you will have little trouble with this problem. Please be sure that the cutter is correctly aligned before you pull the handle to cut.



# Parts List

## COMPLETE RING CUTTERS

- 004-642 Complete Ring Size Cutter  
Includes complete unit  
plus 7 - USA / British cutters
- 004-643 Complete Ring Size Cutter  
Includes complete unit  
plus 9 - Metric cutters

## REPLACEMENT CUTTER KITS

- 004-585 USA / British Cutter Kit  
Includes 7 cutters
- 004-600 Metric Cutter Kit  
Includes 9 cutters

### MAGNETIC STORAGE FOR CUTTERS

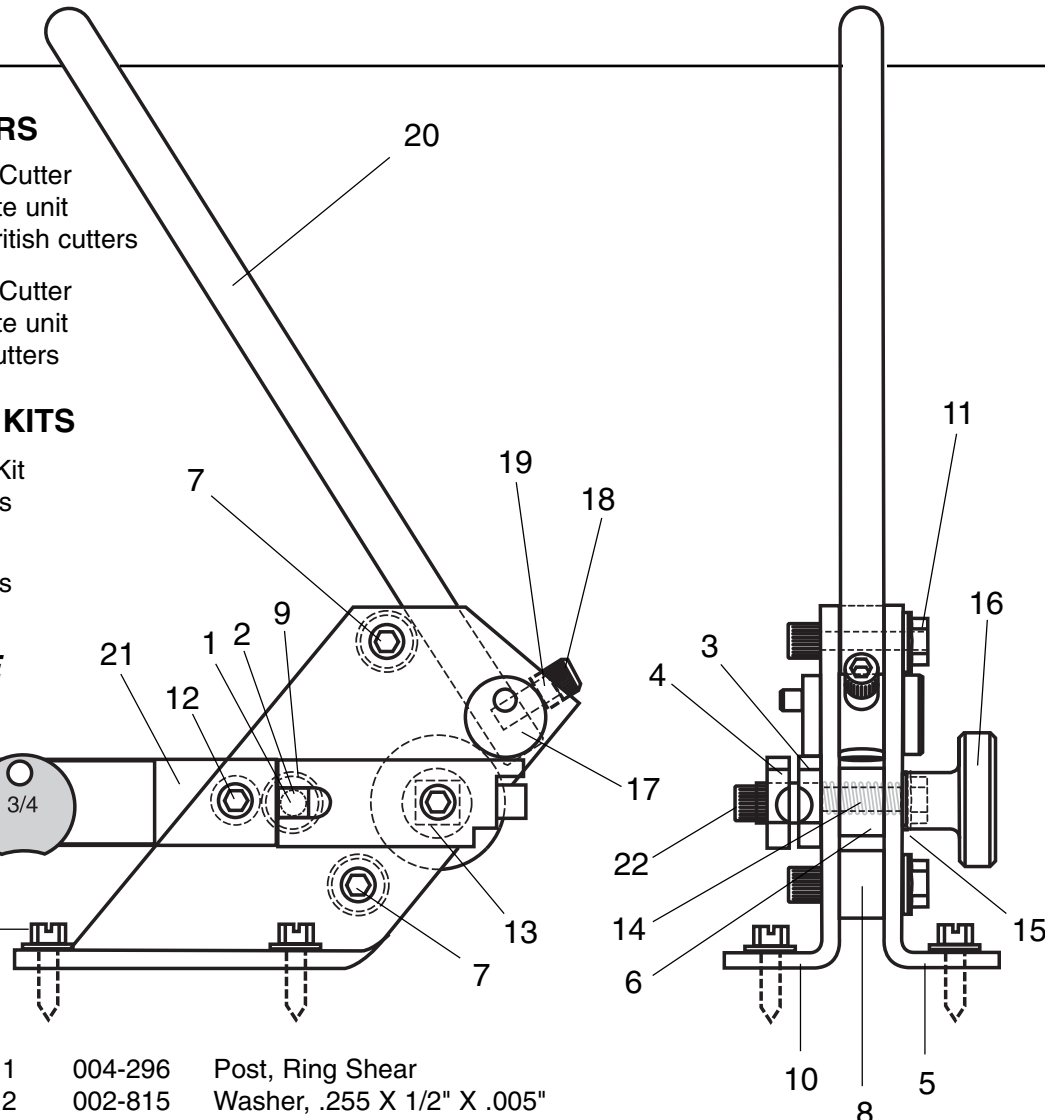
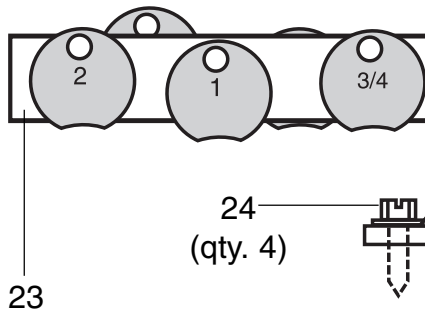

## INDIVIDUAL CUTTERS

	USA	British	WIDTH
004-156	1/2	B#1	.050"
004-157	3/4	B#1.5	.075"
004-158	1	B#2	.100"
004-159	1-1/4	B#2.5	.125"
004-160	1-1/2	B#3	.150"
004-161	1-3/4	B#3.5	.175"
004-162	2	B#4	.200"
Metric			
004-205	1mm		.039"
004-206	1.5mm		.059"
004-207	2mm		.079"
004-208	2.5mm		.098"
004-209	3mm		.118"
004-210	3.5mm		.137"
004-211	4mm		.157"
004-212	4.5mm		.177"
004-213	5mm		.196"

**NOTE:**  
When replacing Cutter Bars -BOTH- should be replaced for the ring cutter to work correctly. Factory replacement recommended.

1	004-296	Post, Ring Shear
2	002-815	Washer, .255 X 1/2" X .005"
3	004-294	Cutter Bar (FIXED)
4	004-295	Cutter Bar (Moveable)
5	004-271	Right Hand Side Plate
6	004-265	Spacer
7	002-900	1/4-20 X 1 1/8" SHCS
8	004-155	Spacer, Ring Shear
9	004-292	Spacer
10	004-270	Left Hand Side Plate
11	002-536	Nut, 1/4-20 Lock
12	002-107	1/4-20 X 1/2" SHCS
13	004-269	Adjustment Shaft
14	002-901	Spring
15	002-962	Spring Washer
16	004-290	Knob
17	004-584	Crank Pin Assembly
18	002-490	1/4-20 X 7/8" SHCS
19	004-195	Spacer, Ring Shear
20	004-150	Handle
21	004-297	Cutter Storage Bar
22	002-489	1/4-20 X 5/8" SHCK
23	050-011	.060 X 1" Magnet Strip
24	002-554	#10 X 3/4" SMS

### NOT SHOWN

- 002-742 3/16" Hex Wrench
- 022-211 10 Compartment Box



To order any part, contact:

**GRS Tools**  
900 Overlander Road  
Emporia, KS 66801, USA

800-835-3519  
Fax: 620-343-9640  
e-mail: Grs@GrsTools.com