

GRS Positioning Vise INSTRUCTIONS

For Engravers And Jewelers Using A Microscope

#003-541

How To Position

First, make sure the vise head is in the center of the vise base. Place the vise directly in the center under the microscope (Fig. 1). Pressing the "Release Lever" will free the vise head so that it may be moved or slide in any desired direction. Release the lever and the vise head locks in place and will rotate from that desired point (Fig. 2). You will quickly learn to position the vise while looking through the scope.

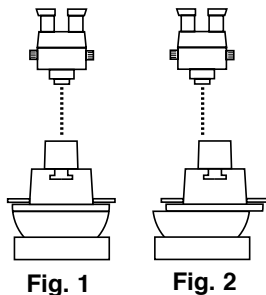

POSITION
RELEASE
LEVER

ROTATIONAL
DRAG
SCREW

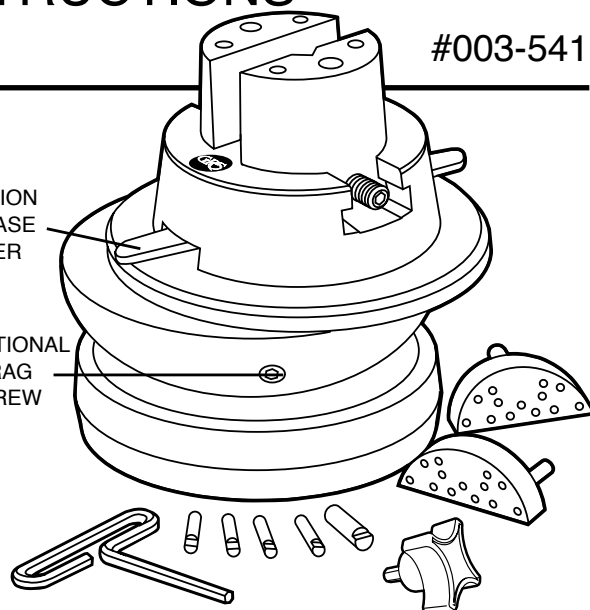

Maintenance

Based on usage, open jaws fully and clean any dirt and metal pieces from the threads. After cleaning, apply a small amount of light oil to the threads.

Wear Repair

Parts that may wear and eventually need replacing are the "Lock Button" (A) located at the center of the position release lever and the "Jaw Thread Pins" (C) located in each jaw.

Loss of Locking Tension

If the vise head does not stay in locked position, you may need to tighten the tension.

1. Loosen the Rotational Drag Screw located on the side of the ball (Fig. 3). Lift the upper portion of the vise out of the base. Turn the vise head upside down and rest it on its top.
2. Remove the four hex head bolts (Fig. 4) from the mounting plate and lift the plate off. Set the bearing / post assembly (Fig. 5) to the side. You can now see the lock button (A) in the center of the lever handle.
3. Remove the lock button with a small screwdriver by prying it up. The button should have a 3/32" flat in the center of the crown. **If the button is damaged or excessively worn**, we recommend replacing it. If it looks in good shape, you can add tension by placing shim washers (B) under the button. This will raise it to create more locking tension.
4. Reassemble the vise by placing the bearing / post in the center of the vise head as shown in (Fig. 5). Set the mounting plate over the bearing/post and align the bolts.
5. Pull the release lever open as you would to move the vise head. Hold it in that position and then tighten the four bolts down. If you don't hold the lever open when tightening the bolts, it will not work.
6. Place the vise head into the base and tighten the ball swivel tension screw (Fig. 3).

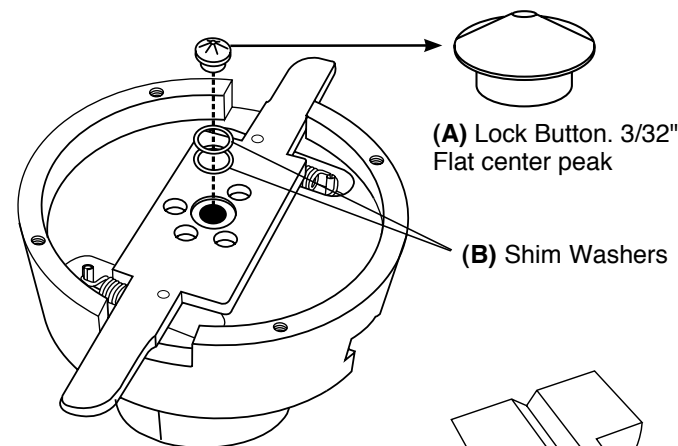
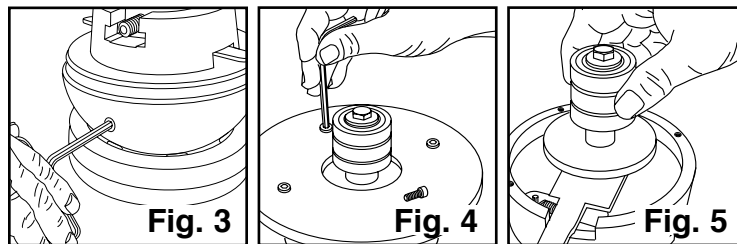

(A) Lock Button. 3/32"
Flat center peak

(B) Shim Washers

Jaw Thread Replacement

Over tightening the jaws will cause wear and damage to the threads. If jaws become loose, replace with kit #003-627. Remove jaws by opening wide until they come off the jaw screw. The thread pin (A) is located on the under side of each jaw. **Before removing pins** locate the left hand pin, marked "L". Replace it with the same. Apply a small amount of grease to the O-rings before installing them. Start the jaws threads at the same time when replacing them. Hold each jaw in position (Fig. 1) and turn the jaw screw. An extra pair of hands makes this easier, or place a large rubber band over the jaws.

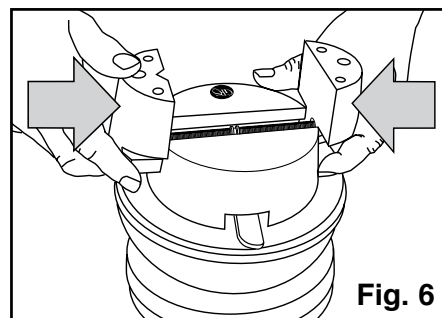

(C) Jaw
Thread Pin

"L" For Left
Hand Thread

GRS Positioning Vise PARTS LIST

For Engravers And Jewelers Using A Microscope

#003-541

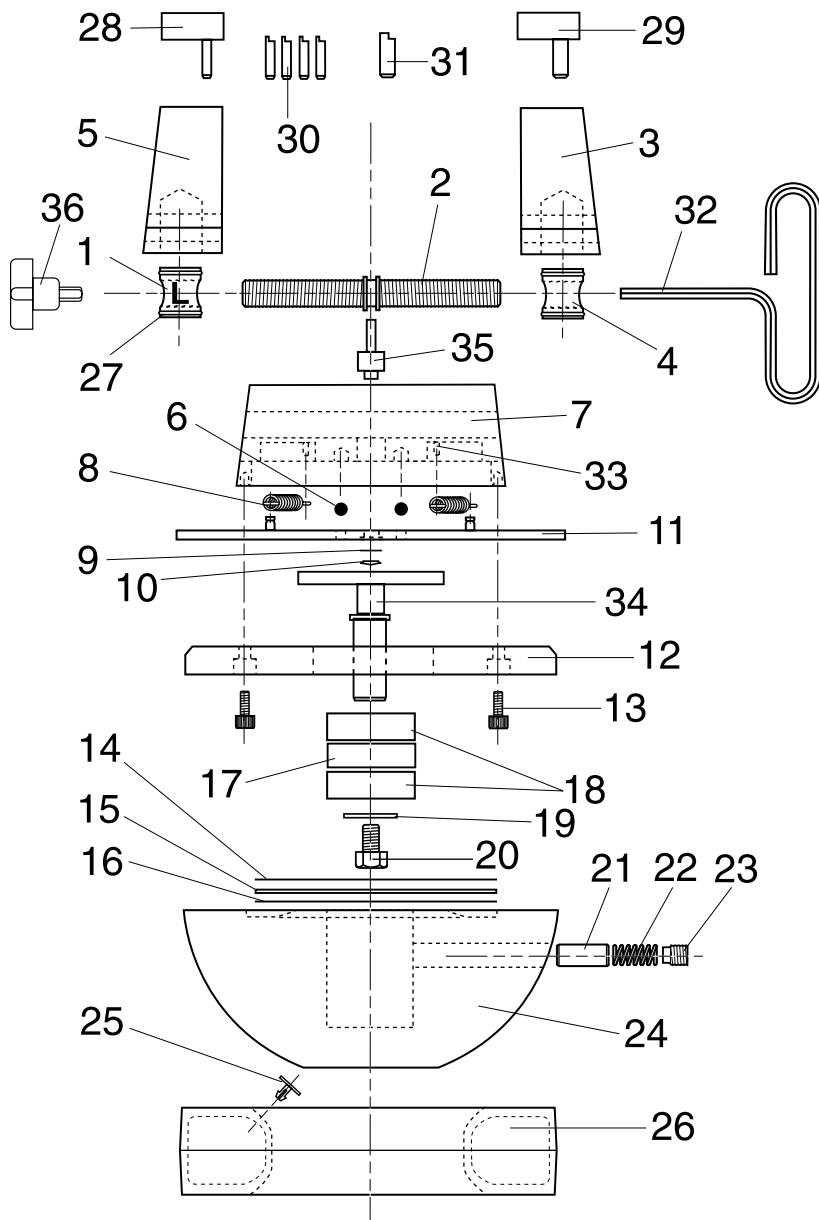

GRS Positioning Vise Complete Assembly #003-541

PART #	DESCRIPTION
1	003-064 Thread Pin, Left Hand
2	003-007 Jaw Screw
3	003-009 Jaw, Right Hand
4	003-065 Thread Pin, Right Hand
5	003-008 Jaw, Left Hand
6	002-450 Bearing 5/16" Steel Ball
7	003-142 Vise Crown
8	003-151 Spring
9	003-206 Shim Washer
10	003-207 Lock Button
11	003-540 Handle Assembly
12	003-148 Mounting Plate
13	002-067 #10-32 x 1/2" SHCS
14	022-171 Thrust Washer
15	022-149 Bearing
16	022-150 Race
17	003-143 Spacer, Drag Pin
18	002-212 Bearing, 5/8" x 1/2"
19	002-214 Washer, 0.312 x 0.859 x 0.125
20	002-112 5/16"-18 x 3/4" HHB
21	003-144 Drag Pin
22	003-020 Spring, Block Drag
23	003-067 1/2"-13 x 1/2" SSS FLT PT HF
24	003-141 Base
25	002-209 Nylon Fasteners
26	003-506 Tire Assembly
27	002-127 O-Ring, 0.625 x 0.75 x.062
28	003-507 Pin Plate Assembly (2 Pin)
29	003-508 Pin Plate Assembly (1 Pin)
30	003-015 Pin, 1/4"
31	003-016 Pin, 3/8"
32	002-091 Wrench 1/4" T Handle Allen
33	002-174 Roll Pin, 1/8" x 3/4"
34	003-538 Post
35	003-146 Yoke
36	003-661 1/4" Hex Drive Knob

Replacement Thread Pin Kit

#003-627 (Not Shown). Includes Jaw Screw, Left and Right Thread Pins, O-Rings, and Tube of Grease.

GRS

900 Overlander Road
P.O. Box 1153
Emporia, KS 66801 USA
Toll-Free: 1-800-835-3519
Phone: 620-343-1084
Fax: 620-343-9640
E-mail: grs@grstools.com
www.grstools.com