

OPERATION AND MAINTENANCE OF THE

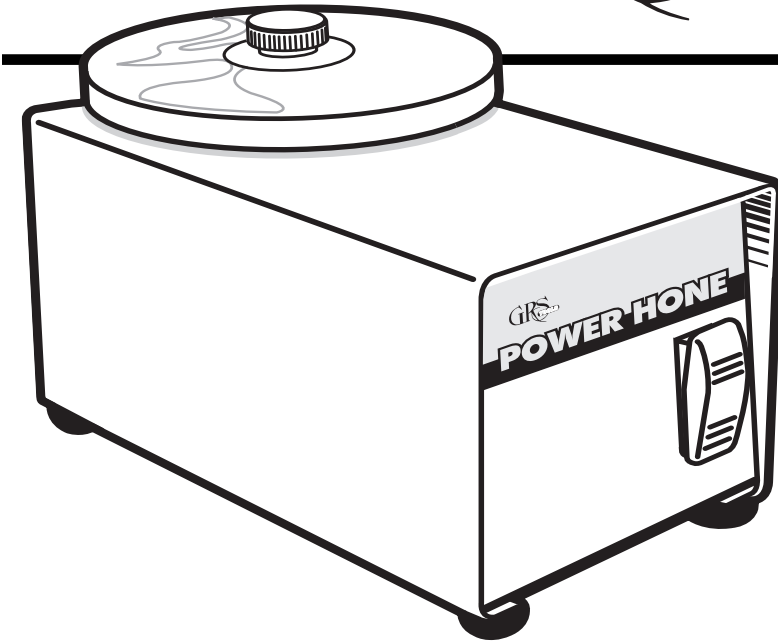

POWER HONE



The GRS Diamond Power Hone is designed for a long, useful service life. The spindle is driven by a smooth belt system at 240 RPM. The diamond wheel supplied with your hone provides true diamond performance. This means carbides, hard metals, ceramics, and other exotic materials are all within the capability of your Power Hone. Replacement diamond wheels are available from GRS Tools in several grits for a wide range of applications.

TOOL SHARPENING

When using the Power Hone, hold the tool relatively stationary while the rotary motion of the wheel sharpens the tool. Sweep the tool slowly across the working surface of the wheel. This extends wheel life by using the entire cutting face and prevents grooving. The Power Hone is designed mainly for fine tool sharpening and finishing. Use a bench grinder to rough shape tool points, then give them a fine finish on the Power Hone. This will save time and extend diamond wheel life.

Engraving & Jewelry Tools

The Power Hone was originally designed to sharpen engraving and jewelry tools. Sharpening fixtures to hold the gravers to the precision angles required for fine engraving tools are available from GRS Tools. See the “accessories” section or the GRS Tools catalog for the sharpening fixtures that are available.

NOTE:

For very delicate work such as heeling small gravers, try using the diamond wheel with the machine turned off. This will prevent removing too much material.

Household & Shop Items

The Power Hone is useful around the house and shop to sharpen items like; scissors, knives, craft tools, hobby tools, chisels, wood and metal lathe tools, etc. With the ceramic lap wheel you can even put an edge on a razor blade.

DIAMOND WHEEL CARE

Diamond wheels provide long term economy and performance in abrasive service if used correctly. Although the diamond is the hardest material known, the bonding which holds the diamond particles in place can be damaged. Grooving the wheel by gouging the bonding material is the biggest error. The finer the grit, the easier it is to damage the wheel. The user should not be afraid to apply moderate pressure while honing, as the wheels are designed for this. The following tips will provide valuable information on using diamond wheels.

1. Approach the diamond surface carefully with the tool. Apply cutting pressure smoothly. Be especially attentive when first cutting sharp points.
2. Wet the diamond surface with a water soluble wetting agent sprayed on with a spray bottle. Occasional spraying to keep surface wet is all that is required. A wet wheel will cut better, yield superior tool finishes, and resist loading.
3. Remove and clean wheel when dirty. Usually scrubbing with water, mild scouring powder, and a clean cloth is sufficient. Our diamond wheel cleaning sticks, #001-783, are designed for a thorough cleaning. These soft abrasive sticks are consumed while cleaning the wheel. Proper use will extend wheel life. We do NOT normally advise using solvents on wheels. If solvents are used, NEVER dip or soak wheel in a solvent. Only wipe top cutting surface and then immediately wash with soap and water. Keep wheel out of direct sunlight and away from excessive heat.
4. Use the entire face of the wheel for cutting.
5. The 600 grit wheel is recommended for general use. It provides a good finish with an adequate material removal rate. Finer grits are normally for finishing operation after using a coarser wheel or other abrasive.

WHEELS AND ACCESSORIES

002-138	5" Dia. - 260 Grit Diamond Wheel
002-055	5" Dia. - 600 Grit Diamond Wheel
002-139	5" Dia. - 1200 Grit Diamond Wheel
002-415	6" Ceramic Lap Wheel

Make your own abrasive /strop wheel. Simply adhere the desired grit of sandpaper or leather to these blank wheels. Wheels are machined to a perfectly flat surface.

002-537	Blank Wheel for Power Hone - 6"
002-129	Blank Wheel for Power Hone - 5"

002-752	Diamond Spray, 1/4 Micron
002-753	Diamond Spray, 1/2 Micron
002-754	Diamond Spray, 1 Micron
002-755	Diamond Spray, 3 Micron

	Wheel Wetting Agent Concentrate
001-659	Pkg of 3 - makes 1 gal. per pkg
001-660	Pkg of 12

001-783	Wheel Cleaning Sticks
001-694	Wheel Storage Rack
001-838	Quick Wheel Change Adapter
001-958	Power Hone Parts Kit

GRAVER SHARPENING FIXTURES

003-100	Standard Graver Sharpening Fixture
003-570	Dual Angle Sharpening Fixture
003-580	QC Sharpening Fixture

FOR PRICING AND MORE INFO CALL:

1-800-835-3519

Fax: 620-343-9640

Tel: 620-343-1084

e-mail: GRS@GRStools.com

Or write: GRS Tools
900 Overlander Road
P.O. Box 1153
Emporia, KS 66801 USA

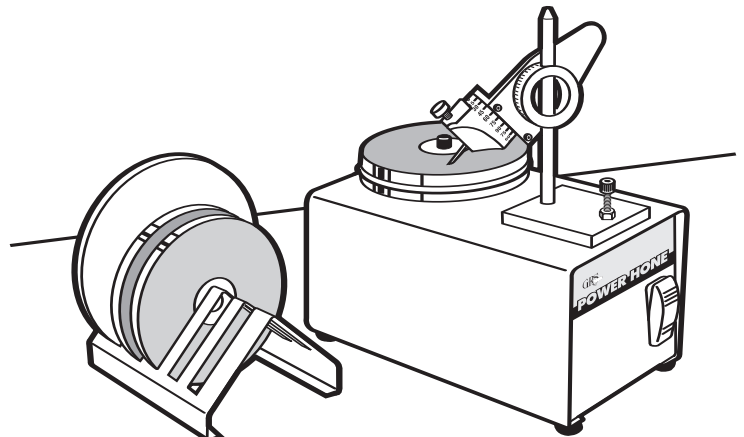

POWER HONE PARTS KIT

Order #001-958

Includes:

- 2 Belts (#20)
- 1 Cleaning Stick
- 1 packet of Wheel Wetting Agent Concentrate (makes 1 gallon)
- 1 Knob Assy., (#1)
- Washer (#22)
- 4 rubber feet with bolts (#14)

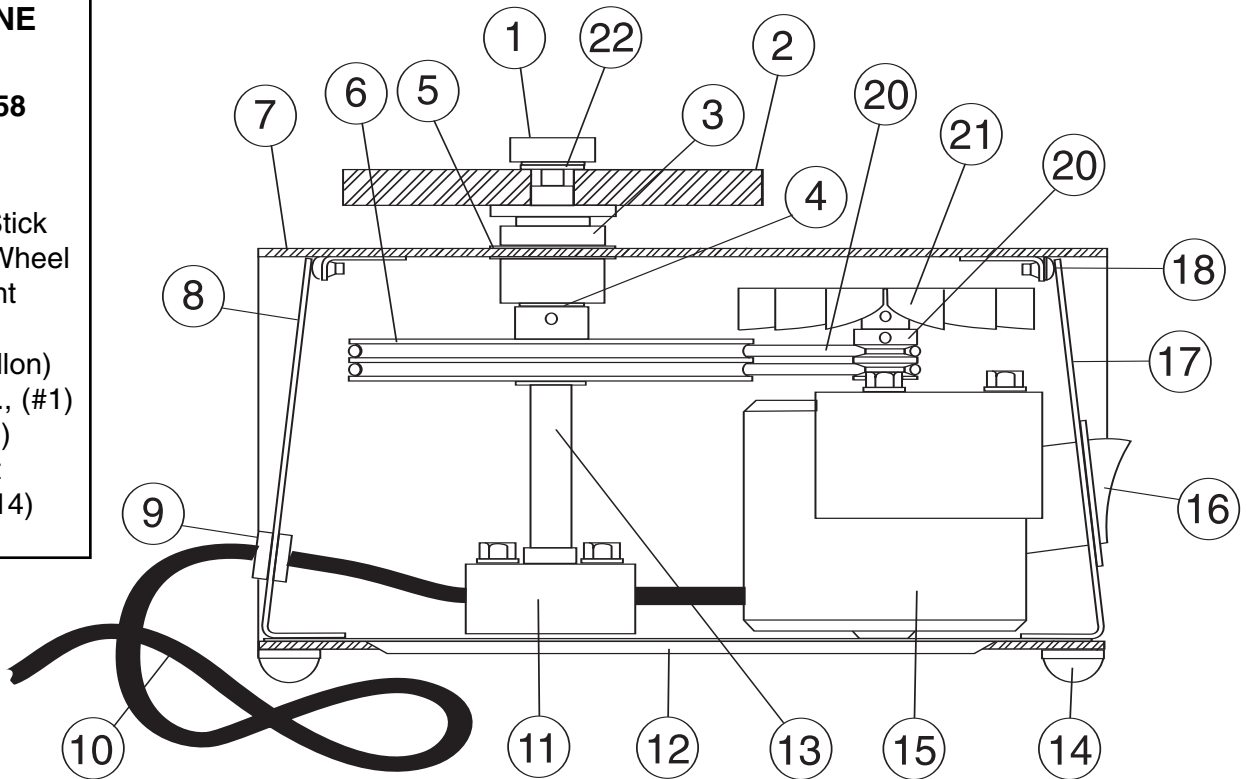

MAINTENANCE

The Diamond Power Hone is virtually maintenance free. For normal service, yearly lubrication is required. For extremely heavy service, the motor should be oiled every 6 months with several drops of SAE 20 non-detergent oil. Oil holes for the two motor bearings are accessible by removing the front switch plate.

⚠ Always unplug machine before any service is done.

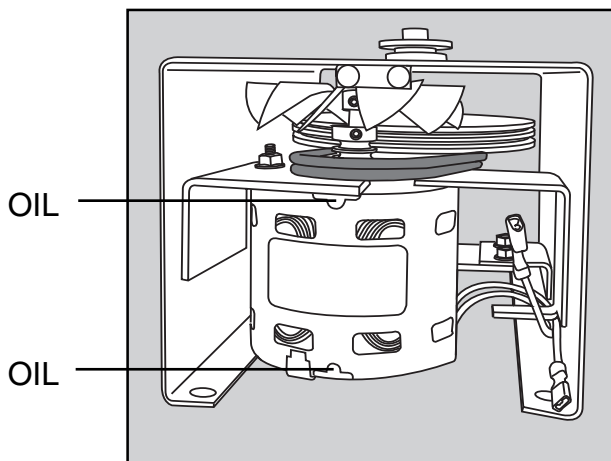

Recommended Oil: SAE 20 weight non-detergent

1	001-534	Knob Assy.
2		Diamond Wheel (see wheel chart at left)
3	001-531	Bushing Housing Assy.
4	002-279	Washer
5	002-135	Snap Ring
6	001-641	Large Pulley
7	001-548	Unitized Hone Body
8	001-086	Cord End Panel
9	002-229	Cord Retainer - 115Volt
	002-952	Cord Retainer - 230Volt
10	001-533	Power Cord Assy. - 115 Volt
	004-650	Power Cord Assy. - 230 Volt
11	001-547	Bushing Plate Assy.
12	001-171	Bottom Vented Panel
13	001-538	Spindal Shaft Assy.
14	002-036	Rubber Feet (4)
15	002-132	Motor - 115 Volt 60 Hz
	002-051	Motor - 230 Volt 50 Hz
16	002-215	Rocker Switch
17	001-105	Switch End Panel
18	002-211	Bumper
19	001-115	Small Pulley
20	002-140	Belt
21	002-131	Fan Blade
22	002-106	Washer

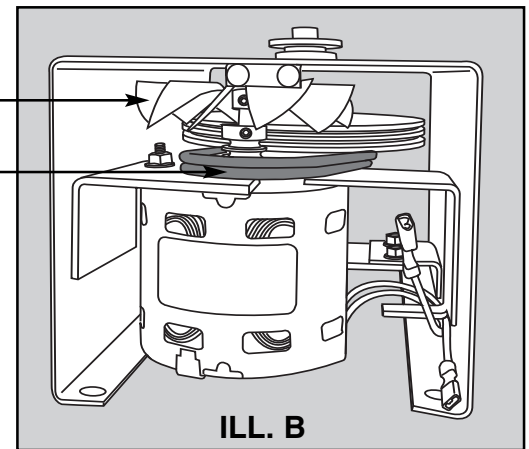
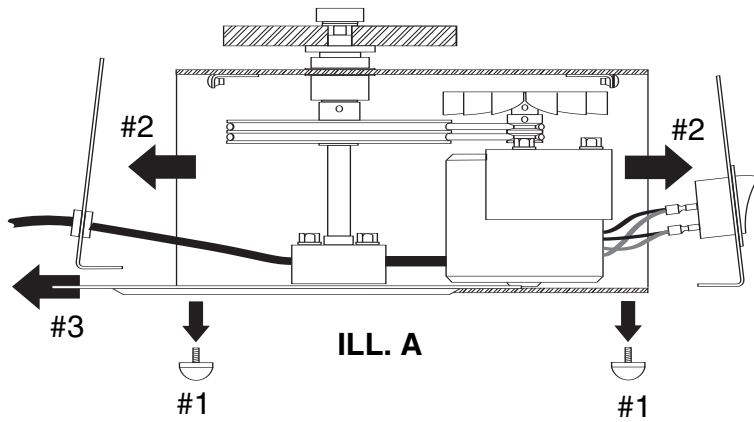

REPLACING THE DRIVE BELTS

These drive belts are made of a special elastic material designed for this service. Regular belt inspections are unnecessary. If you were to notice a drag or loss of power while honing, it may be a broken belt. A spare set of belts is a good item to have on hand. (Power Hone Parts Kit #001-958)

Below are instructions for belt replacement.

Tools Required:

3/32" Allen wrench and a #2 Phillips screwdriver.



UNPLUG THE MACHINE BEFORE OPENING UNIT:
Turning the switch off is NOT sufficient.

**IMPORTANT:
DO NOT LOOSEN
THESE BOLTS**

1. Lay the machine on its side and unscrew the four rubber feet on the bottom of the unit (see ill. A #1).
2. With the rubber feet removed you can work the end panels (switch panel and cord panel) out of the main body (see ill. A #2). Just lay them to the side leaving the wires connected to the switch and the cord panel. You may feed the electrical cord back through the opening for more slack.
3. Slide the bottom vented panel out of the main body (see ill. A #3).
4. REMOVE THE OLD BELTS SIMPLY BY CUTTING THEM OFF.
5. Set the machine upright and from the Switch OR Motor end, drop the new belts down and around the fan blade. Locate them around the pulley wheel on the electric motor. (see ill. B) **Note: End panels were removed in the illustrations to better show detail.**
6. Rotate the unit and work from the CORD end, use a 3/32" Allen wrench to loosen the set screw on the large pulley (see ill. C). NOTE: If your allen wrench is short, you will need to hold the wrench in the jaws of a pair of pliers or vise-grips. Grasp the top of the spindle and pull it out of the main body (see ill. D) just enough to fit the new belts through the opening. Now, push the spindle fully back into the main body. While holding down on the spindle shaft, push up on the pulley wheel and retighten the set screw. The spindle/wheel should turn freely. Note: Be sure to align the set screw on the flat surface of the spindle shaft when tightening.

IMPORTANT: NEVER LOOSEN THE LOWER SPINDLE BUSHING PLATE. IT IS PRECISION ALIGNED AT THE FACTORY.

7. Rotate the unit so it is bottom up. Position the belts first on the motor drive pulley and then work them over the large spindle pulley(see ill. E). Turn the spindle several times by hand to make certain the belts are correctly positioned in the pulley grooves.
8. Replace the bottom vented panel and both ends. Make sure that all wires are securely connected to the switch terminals. Double check to make sure that the bottom vented panel is between the end panels and the main body. Install and tighten the four rubber feet.

