

GRAVERMEISTER^{T.M.}

OPERATION

MAINTENANCE

PARTS LISTING

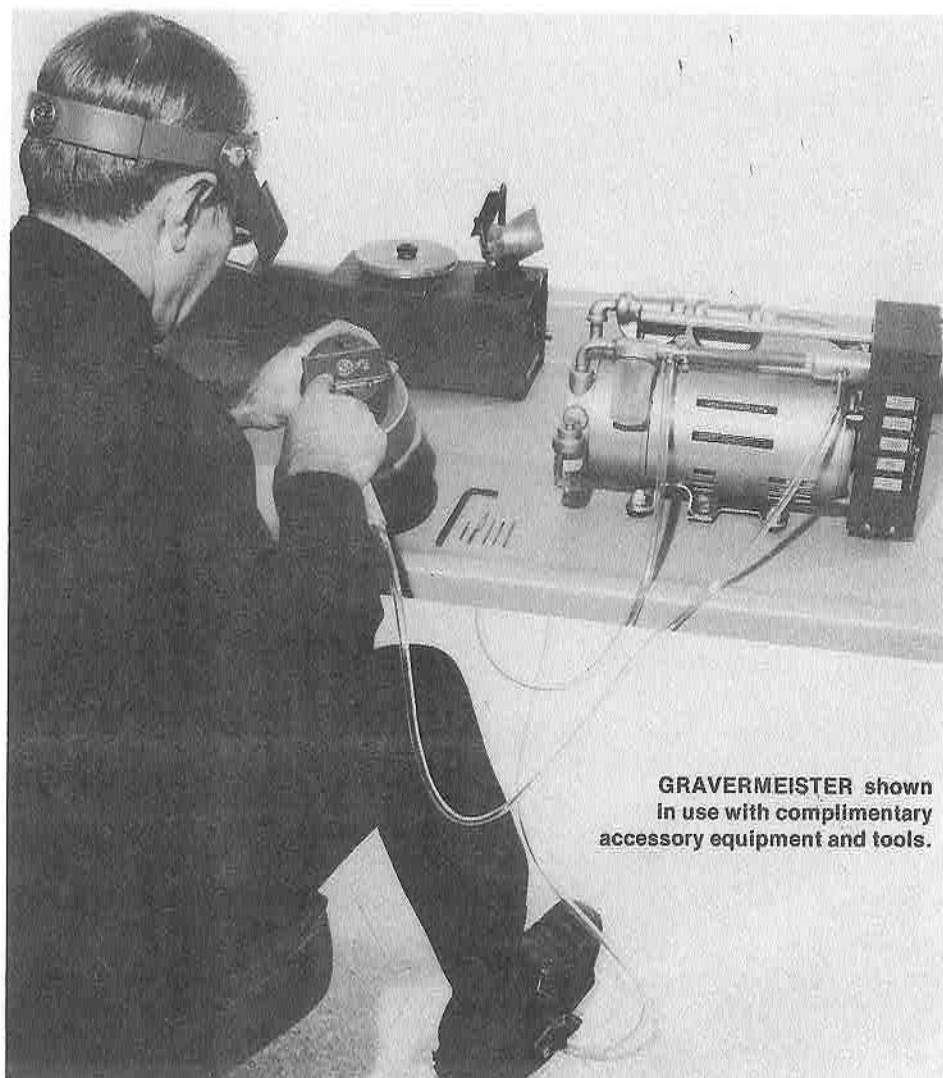

GRAVERMEISTER shown
in use with complimentary
accessory equipment and tools.

GRS | CORPORATION

P.O. BOX 748, EMPORIA, KANSAS 66801

INTRODUCTION

The GRAVERMEISTER fulfills the need for a machine capable of allowing rapid but precise cutting and carving of metal, stone, wood, and ivory, as well as many other materials. The precise impact control feature of the machine also makes it an ideal tool for stone setting, stippling, matt finishing on jewelry, and stipple engraving on crystal, etc.

The skills required to properly operate the GRAVERMEISTER, while not within the ability of everyone, are easily mastered by one who possesses certain obvious, natural skills.

The GRAVERMEISTER acts on the principle of an air-operated hammer capable of delivering controlled impacts at speeds of from 800 to 1200 strokes per minute. The speed of the stroke is varied by positioning an adjusting lever arm. The impact force is controlled by depressing a foot pedal in much the same way the gas pedal on a car is operated.

Because of both the large range of adjustments available, and the precise control possible, delicate cuts can be combined with heavy material-removal cuts for the desired effect.

To realize the full capability of the GRAVERMEISTER, it is necessary for you to become totally familiar with both the operation and proper maintenance of all the components of your machine.

It is also important to become familiar with various proven techniques for use of the GRAVERMEISTER, and the wide variety of tools used to produce the various effects desired. Tool geometry and proper sharpening are as important as skillful use of the GRAVERMEISTER. The first section of this manual is intended to help you avoid many of the difficulties others have experienced in achieving the desired results with the machine. This section is worthy of frequent review until you master both the machine and the proper preparation of the tool, or graver, that does the work.

This manual is broken down into the following four sections:

1. TIPS FOR EFFECTIVE USE OF THE GRAVERMEISTER
2. MACHINE OPERATION
3. MAINTENANCE
4. PARTS LISTING

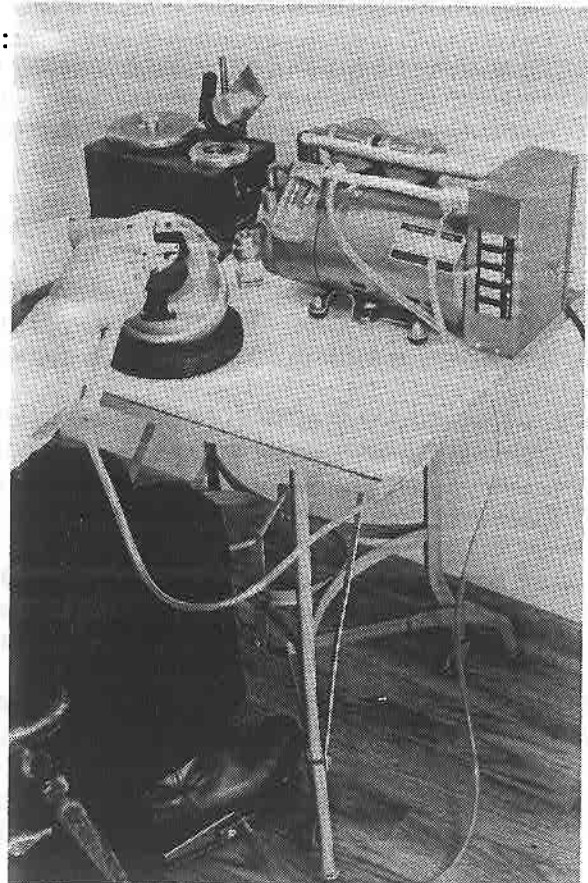

SECTION I

TIPS FOR EFFECTIVE USE OF THE GRAVERMEISTER

1 The GRAVERMEISTER provides an effective, unique method for performing a variety of functions in many materials. You may not achieve effective results with the machine at first. In fact, your initial attempts may be disappointing or downright discouraging! Begin by expecting a learning period — whether you have had experience engraving by another method, or are a novice. This claim is also made: after the initial learning period, the results and the satisfaction derived from use of the machine are fantastic! It takes a little practice, some learning, and perhaps some re-learning. It may seem awkward and ineffective at first — like your first attempt to ride a bicycle — remember?

2 The easiest and most productive way to learn quickly is to work with someone who is accomplished in the use of the GRAVERMEISTER. If this is not possible, we hope the information contained in these "TIPS" will be helpful. A most valuable and useful information source is James B. Meek's book **THE ART OF ENGRAVING**. We recommend it highly.

3 Most of the information in this section is directed toward the task of metal engraving. Even if your purpose for using the GRAVERMEISTER differs, this information is relevant and helpful. The engraving of metal, especially steel, is most difficult and demanding. When the principles of metal engraving are understood, then other uses will be less demanding. We have never known a person who could effectively carve a deep relief scene of the north end of a southbound lion in steel, who could not easily and effectively set a stone, florentine or engrave a ring, matt finish a piece of jewelry, carve wood, or prepare aossil.

4 Here are some reasons why you may not achieve effective results with the GRAVERMEISTER at first:

• The concept of variable power applied to the tool holder, or handpiece, seems strange at first and must be experienced.

• Coordination of power and tool cutting action with the foot throttle might feel awkward, but a small amount of practice makes it natural and automatic.

• It seems strange and different at first — but extremely effective when mastered. Again, remember how easy it was to ride a bicycle after you learned how. Successful cutting requires just the right amount of forward pressure on the handpiece. Too much pressure creates fatigue and impairs tool control. Too little pressure quickly dulls the tool point.

5 Try these techniques — then review results and try them again:

Turn the machine ON, hold the handpiece in your hand, and work the foot throttle to get the feel of the power variation from light, short strokes to heavy, long strokes. You will begin to anticipate the foot throttle position for the various power settings desired.

Be sure the tool is tight in the handpiece chuck. **Work the throttle while tightening or loosening the chuck.** The handpiece action at full throttle will aid in tightening the chuck, and is especially helpful in opening the chuck to remove the tool. The chuck nut seems to tighten during use, and the handpiece action makes it possible to remove the tool easily.

When cutting or engraving, hold the handpiece as you would a table knife — not as a pencil. Place your index finger on the graver, or chisel, as you would on a knife blade to exert slight downward pressure. You hold it like a pencil only when stippling, background matting, chipping, etc.

Place the tool cutting point on the work piece **before** applying power with the Throttle. Attempting to enter the cut with the power ON and the handpiece stroking will quickly dull the tool point.

Apply power with the Throttle only **after** positioning the tool on the work. Use slight forward pressure to keep the tool point moving forward into the cut. Both tool angle and downward pressure control

depth of cut. Too much downward pressure will tire you, though.

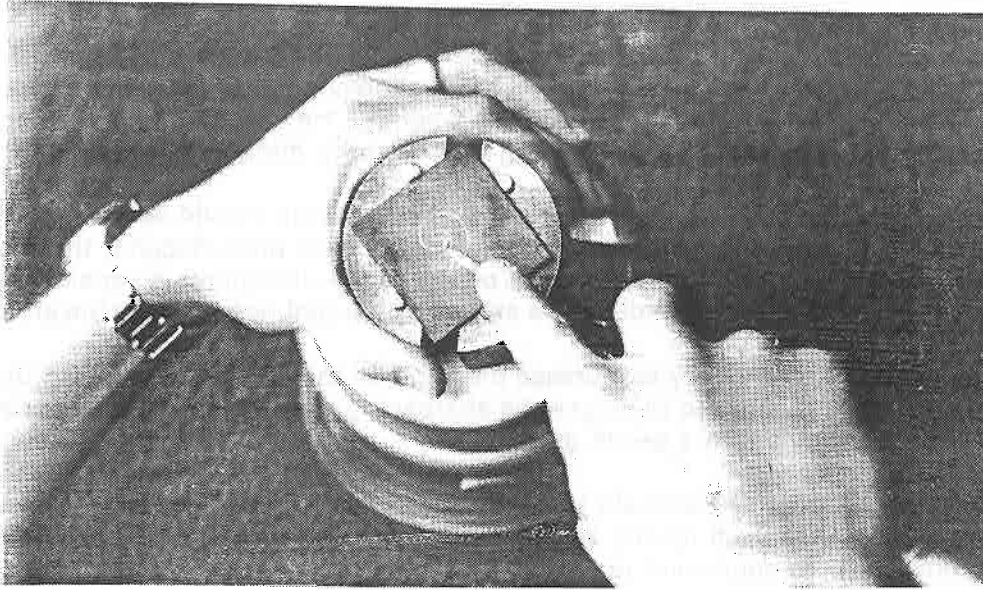

- F. Vary the power input with the Throttle to control the speed and depth of cut. Do not let the cutting action get ahead of your ability to guide the tool. Stop the throttle action to reposition the work. Leave the tool point in position in the cut.
- G. Overcome the tendency to let the Handpiece continue to stroke when not actually cutting (by failing to manipulate the Throttle). With practice, control of the Throttle becomes an automatic response.
- H. Use a stable vise, or heavy engraver's block to hold the work. If the work is not held solidly, vibration will decrease effectiveness of the machine power and will more quickly dull or chip the tool point. The GRS MAGNABLOCK is the most effective work-holding block, allows the needed rotation of the work, and was designed for use with the GRAVERMEISTER.
- I. Don't push hard! If your hand becomes tired or cramped, you aren't using the power of the machine to do the work — or you may not have the tool properly sharpened or heeled.
- J. Keep the tool sharp and properly heeled. Sharpen frequently — before you lose the point entirely. With practice you will begin to "feel" when the point is beginning to dull. At this time, only a slight amount of sharpening is necessary to bring it back to the desired sharpness. Hardness of the material you are cutting will greatly affect tool life.
- K. There should be no noticeable vibration of the tool point in the cut. If the point is allowed to vibrate in the cut, the point will dull quickly.

THE IMPORTANT TOOL SHARPENING TECHNIQUES

1.6 While the GRAVERMEISTER is a tremendous aid in solving the most difficult task in engraving or carving, it does not help in another important area — the task of tool sharpening. In fact, it perhaps even emphasized that problem. You will be cutting faster and deeper, and point geometry and condition will soon become apparent. Be prepared to go through a learning period in the tool sharpening task. Here too, a few minutes spent with someone who knows how to sharpen tools properly can save hours of frustrating experimentation. A word of caution though! **BE SURE YOUR ADVISOR REALLY KNOWS.**

1.7 If a session with someone who knows how is not possible, read the following information — and practice. In the end, **you** must learn effective technique so that when you put the tool into the work, you **know** the result will be as you planned.

SECTION I

3 Various types of gravers are used for different types and styles of cutting, but the square and point (oglette) are the most important in metal cutting, and once you master the sharpening techniques for them, you should have little difficulty with others.

4 In his book, **THE ART OF ENGRAVING**, Mr. Meek's excellent illustration and discussion of the importance of proper tool sharpening technique and geometry is especially helpful. He relates to this subject in chapters 2, 4 and 7. This subject is of utmost importance, and this reference material is most helpful.

5 Gravers should be ground on the face first. The approximate 45 degree angle should be maintained. Keep the graver in the handpiece for free-hand sharpening. First, this will save time. Second, the additional length provided is an aid in maintaining the proper angle on the stone. It requires a considerable amount of care and practice to maintain the proper angle while sweeping the tool point across the stone.

6 A common error in sharpening is the tendency to increase the angle of the face gradually each time the graver is resharpened. To help prevent this and to reduce the sharpening time, it is helpful to remove some of the excess material near the point with a bench grinder.

7 GRS sharpening equipment is a most valuable aid in tool sharpening. It is especially helpful for beginners in the art of engraving, and has been readily accepted by accomplished engravers who have found that it is faster and produces more consistent results.

The GRS Power Hone is a valuable aid. Since the stone or lap rotates, it is necessary only to hold the graver at the correct angle, but sweep it slowly across the stone or lap to prevent grooving the stone. You may leave the graver in the handpiece as the added length provides a convenient handle. Finish the sharpening process with a few strokes on a fine, hard stone or polishing paper.

The combination of the GRS Power Hone and the Sharpening Fixture provides the ideal sharpening system. The Sharpening Fixture is designed specifically for use with the Power Hone. With this combination, you can sharpen repeatedly with consistent results time after time. It is easy to learn — you merely follow the instructions. A square graver can also be "heeled" with the fixture.

8 For good results, the graver must be heeled, or set-up. This task takes some experimentation and practice to produce satisfactory results. The finish of the engraved cut is greatly affected by the finish of the graver heel. For a bright cut, finish the heel using polishing paper. Here is what the heel accomplishes:

It raises the working angle of the graver to the work surface to a convenient height.

It provides depth control.

It gives clearance when working on irregular surfaces, and prevents the bottom surface of the graver from dragging on the edges of the cut when making curved cuts.

It improves the quality and appearance of the cut.

Usually a heel angle between 10 and 20 degrees is used. Only a small amount of material need be removed. A few light strokes on a fine, hard stone is sufficient. Don't be confused by the tremendous number and variety of gravers available in the supply catalogs; virtually all work can be accomplished with small variety of points.

TIPS FOR PRACTICE SESSIONS

1.14 Start with simple cuts. Using a square or point (onglette) graver, begin by cutting straight lines — then simple curves. Practice depth control, cutting both fine shallow lines, and deep cuts. It is good practice to master the technique of varying the depth of cut to produce a pleasing shaded effect. These practice sessions will help you acquire the necessary skills in both tool control and tool sharpening technique.

1.15 After you have mastered the basic skills, you can concentrate on learning the more difficult and intricate designs. With confidence in your ability to control the tool, you will be able to execute progressively more difficult patterns with varying depth of cut and subtle shading — and finally on curved or irregular surfaces.

1.16 Simple exercises like those sketched below are good beginning practice designs as they are relatively simple. It is easy to determine the progression of the cuts to generate the design, and they do not require a large amount of rotation or manipulation of the work piece. This type of design is also good practice for the beginning woodcarver.

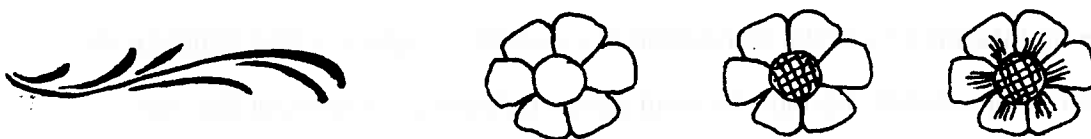
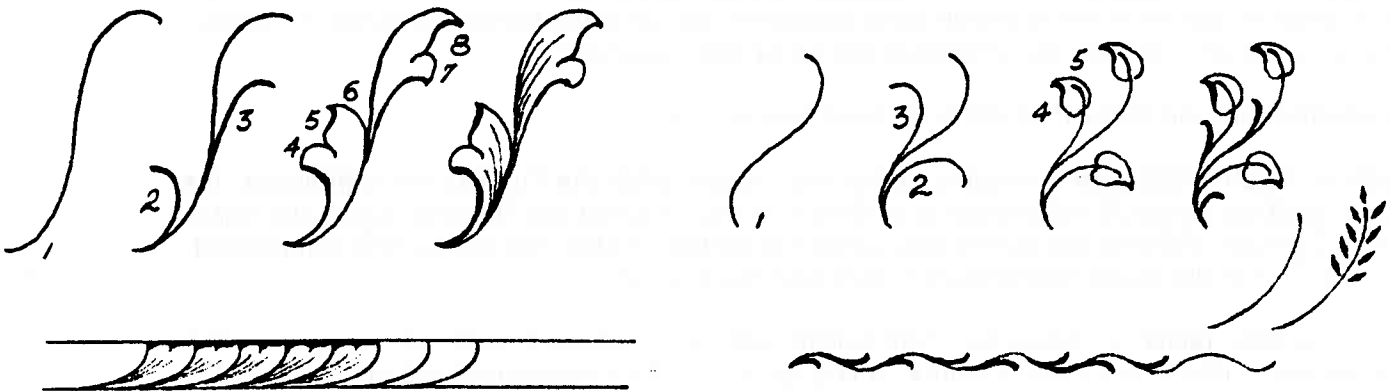

SECTION II

SECTION II

MACHINE OPERATION

The operation section is divided into the following five parts:

- (A) MACHINE STARTUP
- (B) HANDPIECE
- (C) THROTTLE
- (D) STROKE SPEED CONTROL
- (E) PUMP

1 MACHINE STARTUP

The GRAVERMEISTER has been completely checked out and set for proper operation at the factory. It is shipped with the Throttle, Handpiece, and accessories disassembled and packed separately in the carton. The hoses are connected in proper location on the machine. To unpack:

- 1. Remove the machine from the shipping carton.
- 2. Install the Foot Support Assembly on the Pump Mount. (Refer to instructions on the foot support package for proper installation).
- 3. Fill Oil Jar about 3/4 full, using the oil provided in the accessory package. The GAST information packet attached to the unit also contains a list of approved oils for use in the machine.
- 4. Connect the Throttle and Handpiece on the hoses provided on the machine. The Handpiece hose is the shorter one which connects to the machine valve assembly. **Do not interchange the hoses.** The handpiece hose must be shorter than the Throttle hose for proper operation.

Turn the machine ON and allow it to warm up for a few minutes.

Work the Foot Throttle and note the action of the Handpiece. With the Throttle not depressed, the Handpiece should not stroke. If it does stroke slightly with your foot off the Throttle, adjust the Handpiece Spring Tension. Refer to the Handpiece operation section in this manual for this adjustment. Note: Make sure that the power bleed valve is screwed down firmly.

The machine is now ready for operation, but please familiarize yourself with all sections of the manual, and keep it handy for future reference. It is a valuable aid for successful use of the GRAVERMEISTER.

2 HANDPIECE

The GRAVERMEISTER Handpiece is that portion of the machine which acts as an air-driven hammer, and is used to hold and provide power to the tool. It consists of the Chuck and Body Assembly, Piston, Spring, and Air Connector. Two Handpieces are available for use with the GRAVERMEISTER, and they are easily interchanged. The small Handpiece is the most universally used for engraving, jewelry manufacturing, stippling, etc. The large Handpiece is used more frequently for woodcarving, fossil preparation, and heavier material removal work requirements.

The Handpiece Chucks are designed to hold a wide variety of gravers, liners, wood chisels, chippers, etc. Maximum tool shank diameter for the large Handpiece is 1/4 inch. Maximum tool shank diameter for the small Handpiece is 5/32 inch.

The Chuck Body is an integral part of the Handpiece and cannot be removed as a separate unit.

The Piston is the stroking element. Its reciprocating action delivers the impact to the tool.

The Spring holds the Piston in its proper position in the Handpiece body and is an important element

in the stroke control characteristics of the machine.

E. The Air Connector serves a two-fold purpose:

1. It is an air inlet to the tool, and
2. It is used as an adjusting device for proper tensioning of the Piston Spring.

2.3 OPERATING TECHNIQUES

A. When inserting the desired tool into the Chuck, it is not necessary that it be aligned perfectly; however, it must be firmly seated inside the Chuck, on the face of the Chuck, or on the ledge provided in the Chuck Jaws (small handpiece only). This will prevent slippage and transmit maximum impact to the cutting edge. Gravers must be firmly seated in the chuck, on the face, or on the ledge provided in the chuck jaws. This will prevent slippage and transmit maximum impact to the cutting edge.

Note: Large handpiece has no ledge and the short square gravers, small points, etc. cannot be readily used.

Standard gravers normally used with wood handles (point, knife, liners, etc.) may be used in all handpieces. The tang (or shank) end must be modified by grinding to fit the chuck properly. These gravers are clamped between the chuck jaws with the tang end inserted to the bottom of the chuck. Gravers of this type furnished by GRS Corporation are modified to fit and may be used as a guide for modifying gravers you already own or purchase from other sources.

The following sketch shows how the graver should be modified.

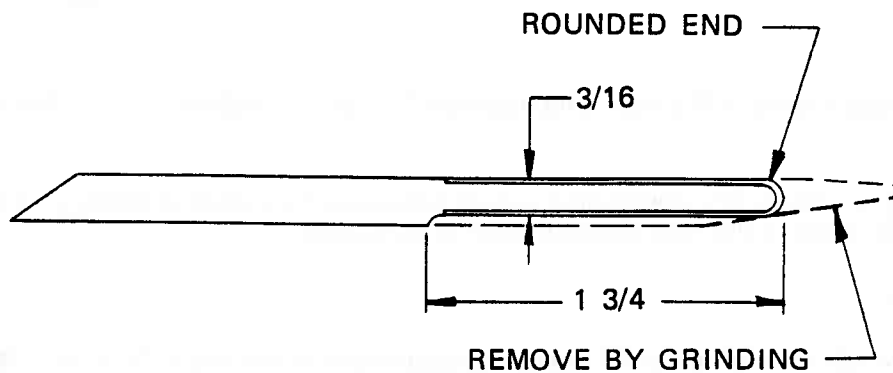

CAUTION

Do not use tool bits with a sharp tang, as the tang will damage the bottom of the chuck. Grind the sharp point off.

Do not use tool bits with a taper larger than the Chuck will easily accept. If the tool bit shank is so large that it will not "bottom out", the impact during use will wedge the tool into the Chuck so tightly that the Handpiece may be damaged when trying to remove the tool bit. Grind any excessive taper from the tool bit shank.

- B. Always be sure that the tool point is sharp. Sharpness enhances cutting control and allows crisp, clean material removal. Refer to the TIPS section of the manual for further information on sharpening technique.
- C. Hold the Handpiece like a knife or scraper, not like a pencil. In this manner, more of your hand is in contact with the Handpiece, giving you better control.
- D. Hold the Handpiece firmly, but you need not grip it tightly.
- E. Do **not** push hard on the tool while cutting. Because of the reciprocating impact action of the machine, it requires only **slight** forward pressure.

SECTION II

- . The depth of the cut is controlled by varying the angle of approach of the tool to the workpiece. After the cut is started, decrease the angle and maintain sufficient downward pressure on the tool to keep it from slipping from the cut.
- . For best control, the workpiece must be held as firmly as possible. If it is not, much of the power and cutting capability of the tool is lost. When cutting curved lines, it is best to use either an engraver's ball or a vise which can be rotated with your free hand to position the work as the cut progresses. We recommend the GRS MAGNABLOCK.

4 ADJUSTING THE HANDPIECE

To adjust the Handpiece for proper spring tension and proper operation, use the following procedure:

1. Turn the machine ON. Do not depress the Throttle.
2. Hold the Handpiece with the Chuck pointing upward.
3. Loosen the knurled retaining nut on the Hose Connector and slowly unscrew the Hose Connector until the Handpiece begins to stroke lightly.
4. Now screw the Hose Connector slowly into the Handpiece body to a point where the machine stops stroking.
5. To keep the Hose Connector from loosening, tighten the knurled Retaining Nut against the Handpiece body.

5 THROTTLE

DESCRIPTION

The Throttle controls the impact force of the tool. The more the Throttle is depressed, the greater the stroke impact.

The Throttle is essentially an air valve. The depressing action progressively closes a vacuum valve. As this valve closes, vacuum to operate the Handpiece Piston is increased.

OPERATING TECHNIQUES

1. The ability to exercise precise control under all operating conditions is the most important feature of the GRAVERMEISTER. Coordination of the Throttle and Handpiece is very similar to steering your car while depressing the gas pedal.
2. Place the cutting point of the tool in position before depressing the Throttle. Stop the stroking action before repositioning the tool, or at the end of a cut. Then, lift the tool from your work.
3. Use sufficient impact force to perform the cutting with a minimum of hand pressure. (If your hand and arm become tired quickly, you are pushing the tool and using too light a stroke.) Remember, the machine does the cutting. Use only enough hand pressure to maintain complete control over the cutting edge. If the tool bit slips out of position and gouges your work, you are using too much hand pressure.

3 STROKE SPEED CONTROL

The Stroke Speed Control is mounted on the side of the GRAVERMEISTER. The speed of the stroke is adjustable from 800 to 1200 strokes per minute. Some materials cut so fast that a slower stroke setting is desired to allow good control. Other materials cut better and give longer tool life at higher speeds. The best way to learn the proper speed for any given application is by experimenting.

A Variable Sheave Assembly provides the variable speed capability to the rotating air valve. This air valve, in turn, controls the handpiece stroking rate.

2.7 OPERATING TECHNIQUES

Stroke speed is a matter of personal preference and experience. Generally, a medium speed is desired; however, there are two conditions under which slower stroke speeds are more fitting:

- A. When using a beading, matting or staking tool.
- B. For cuts requiring maximum power. This is an inherent characteristic of the speed/power relationship in the machine.

NOTE

Change speed settings while the machine is running. This practice increases belt life.

2.8 PUMP

A. DESCRIPTION

The Pump is the power source of the GRAVERMEISTER. It is a specially designed and constructed combination vacuum/pressure pump. The Pump, which is a rotary-vane type, is combined with the motor to form a very compact unit.

- B. The Vacuum inlet of the Pump is equipped with a Filter and contains a hose fitting for the Throttle inlet.
- C. A Power Bleed Valve is also located on this fitting. This Valve reduces the maximum impact power of the machine when it is unscrewed. This provides more precise control for delicate work (it acts like a governor).
- D. For normal operation, this Valve should be closed for maximum power range. To adjust for reduced maximum power, open the Valve until maximum power is reduced to the desired level. Limiting power in this manner makes the Throttle less sensitive and easier to control for delicate work.
- E. The pressure outlet of the pump is provided with two special Muffler/Filters. The first Muffler/Filter contains a filter element for cleaning the pump exhaust air. The second Muffler/Filter contains a Pressure Relief Valve set at the factory for 9 P.S.I. **DO NOT ADJUST THIS VALVE.** Be sure the aluminum jars are tight to prevent leakage.

SECTION III

SECTION III

MAINTENANCE

The maintenance section is divided into the following four parts:

- (A) HANDPIECE
- (B) THROTTLE
- (C) STROKE SPEED CONTROL
- (D) PUMP

1 HANDPIECE

The Handpiece must be kept clean for proper operation. It must "breathe" through the bleed holes around the Handpiece body. If the Handpiece operation becomes sluggish, erratic, or fails to operate, it may need cleaning.

To clean the Handpiece:

1. Remove the Hose Connector, Spring and Piston, and clean all parts thoroughly with solvent.
2. Reassemble and adjust according to the instructions in the HANDPIECE OPERATING TECHNIQUES, and also found in item 3 below.
3. Do not oil the Piston or bore of the Handpiece. Oil will soon become gummy and cause erratic handpiece action.

Oiling — Occasionally place a drop of oil on the Handpiece Chuck threads and Jaws. This will extend the useful life of the Chuck components, and make them easier to open and close.

Adjusting the Handpiece — To adjust the Handpiece for proper operation, use the following procedure:

1. Turn the machine ON. Do not depress the Throttle.
2. Hold the Handpiece with the Chuck pointing upward.
3. Loosen the knurled Retaining Nut on the Hose Connector and slowly unscrew the Hose Connector until the Handpiece begins to stroke lightly.
4. Now screw the Hose Connector slowly into the Handpiece body to a point where the machine stops stroking.
5. To keep the Hose Connector from loosening, tighten the knurled Retaining Nut against the Handpiece body.

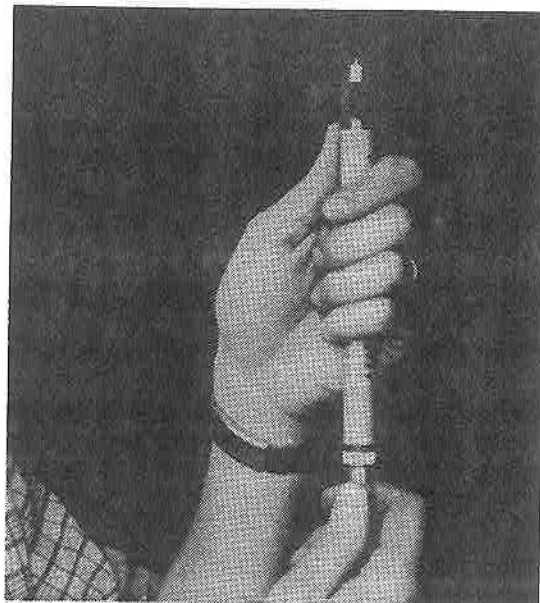

THROTTLE

Cleaning — The Throttle should require little maintenance. However, if operated in dusty or dirty conditions, it may be necessary to clean the valve inlet periodically. The valve inlet is located inside the hinge plate, directly opposite the Throttle Valve inlet.

Oiling — Periodically place a drop of oil on the Throttle Hinge and the sliding surface of the Throttle outlet and Throttle Hinge Plate.

3.3 STROKE SPEED CONTROL

- A. Cover removal — To remove Cover, loosen the screws on each side of the Cover and lift off. It is necessary to spring the Cover open slightly to clear the Idler Arm.

NOTE

When installing the cover, be sure the locating flanges at the top properly engage the switch cover and back plate.

- B. Switch Cover removal — Two screws fasten the Switch Cover to the Back Plate. If it becomes necessary to remove this Cover, the switch must also be removed; however, most maintenance can be performed without doing so.

WARNING

BE SURE TO UNPLUG THE MACHINE BEFORE WORKING IN THIS AREA.

- C. Belt removal — The Belt can be easily removed by positioning the Idler Arm to 1200 and rolling the Belt from the Valve Sheave. When installing the Belt, place it around the Variable Sheave and pull on it, just enough to expand the Sheave and allow the Belt to be placed on the Valve Sheave.
- D. Valve disassembly — With the Belt removed, the Valve Rotor can be easily removed by sliding the Valve Sheave and Rotor out of the Valve Body assembly. The Rotor is retained in position by vacuum generated by the Pump.
- E. Oiling — The speed stroke components should not require oiling. If the Valve is disassembled and cleaned, a drop or two of oil should be used. During normal operation, the oil vapor from the Pump keeps the Valve lubricated.

3.4 PUMP

- A. Vacuum Filter — The Vacuum Filter may be visually inspected for dirt. Clean the glass jar periodically to prevent the possibility of foreign particles passing through the Pump. Remove the felt filter elements occasionally and clean them with a solvent.

CAUTION

ALWAYS BE SURE ALL FILTER JARS ARE TIGHTLY INSTALLED. A LEAK CAUSES A DRASTIC REDUCTION IN MACHINE PERFORMANCE.

- B. Muffler/Filter Jar — Periodically remove and clean the aluminum Muffler/Filter Jar. Excess oil passing through the Pump may condense in the jar. Do not reuse this oil. The Pressure Relief Valve (inside the second jar) is set at the factory for the proper operation pressure of 9 P.S.I. No further adjustment of this valve should be made.
- C. Oiling — Use the oil shipped with the unit. For additional oil, consult the Pump manual which is supplied with the unit.
- D. Maintenance — For satisfactory performance of the Pump, consult the Pump manual for any maintenance required. A local GAST distributor may be near you, and can supply replacement parts. GRS also maintains a full complement of parts.

NOTE

A considerable amount of heat is generated by the Pump, especially on the pressure side. This is normal. The Muffler/Filters will normally become so warm that they are uncomfortable to touch. This is due to the heat rise associated with the compression of air. Also, you may sometimes note a slight oil vapor odor. This is also normal. The Pump is lubricated by passing oil through the Pump. Oil consumption is not great. A full oil jar will last a number of hours, and will vary considerably between intermittent operation and continuous operation. Variable oil consumption is also normal.

GRAVERMEISTERTM

PARTS LISTING

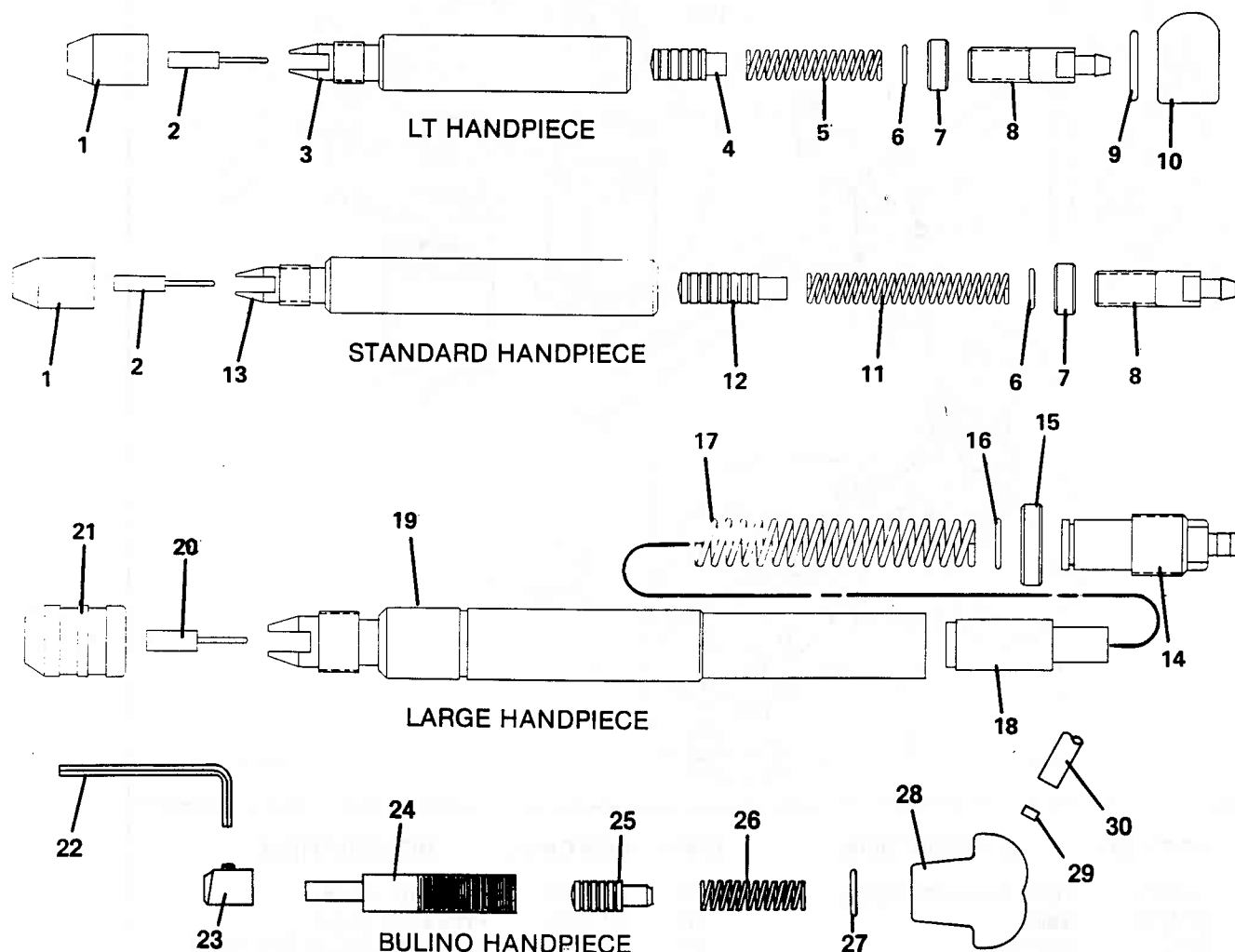

ITEM	PART NO.	DESCRIPTION	ITEM	PART NO.	DESCRIPTION
1	01-463	Chuck Nut	17	01-304	Spring
2	01-196	Chuck Jaw	18	01-305	Piston
3	01-526	Handpiece Body Assy.	19	01-601	Handpiece Body Assy.
4	01-004	Piston	20	02-093	Chuck Jaw
5	01-225	Spring	21	02-094	Chuck Nut
6	02-084	O-Ring	22	02-605	5/64" Allen Wrench
7	01-072	Lock Nut	23	04-566	Graver Retainer Assy.
8	01-056	Inlet	24	04-565	Handpiece Body Assy.
9	02-194	O-Ring	25	04-119	Piston
10	01-227	Knob	26	04-125	Spring
11	01-078	Spring	27	02-590	O-Ring
12	01-057	Piston	28	04-122	Knob
13	01-535	Handpiece Body Assy.	29	04-131	Hose Retainer
14	01-307	Inlet	30	04-049	Handpiece Hose (Bulino Handpiece)
15	01-309	Lock Nut	31	01-044	Handpiece Hose (LT, Standard & Lg. Handpiece)
16	02-127	O-Ring			

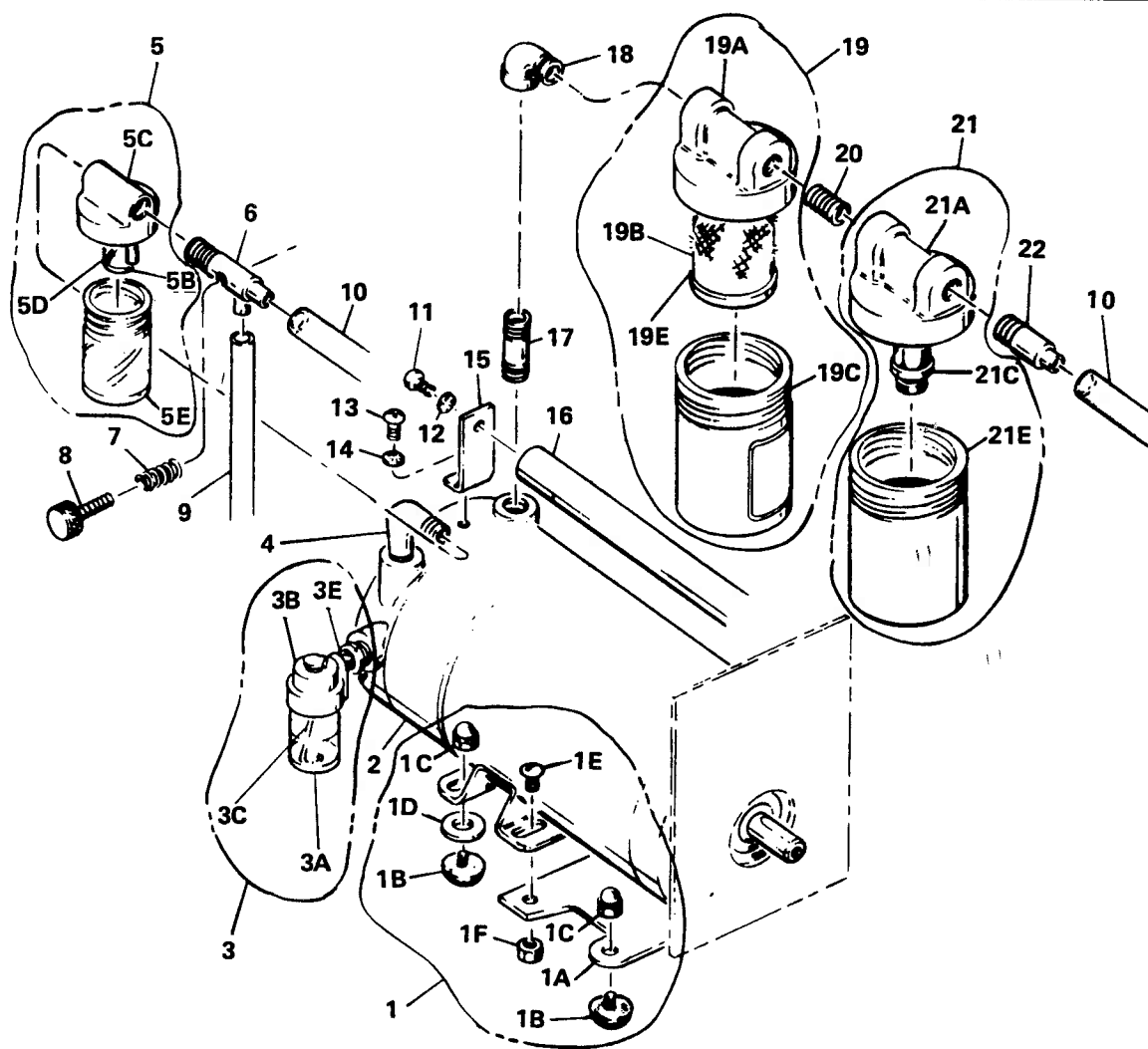

ITEM	PART NO.	DESCRIPTION	ITEM	PART NO.	DESCRIPTION
1	02-024	Foot Support Assy.	9	01-050	Throttle Hose
1A	02-018	Base	10	01-045	Pressure Hose
1B	02-019	Bumper	11	02-112	5/16-18 UNC x 3/4 HHB
1C	02-020	Nut	12	02-106	1/4 Flat Washer
1D	02-021	Washer	13	02-066	10-32 UNF x 1/2 R.H.M.S.
1E	02-022	Screw	14	02-110	#8 SAE Washer
1F	02-028	Nut	15	01-051	Handle Bracket
2	01-575	Pump Assy. (mod.)	16	01-221	Handle
3	02-097	Oiler Assy.	17	02-201	Nipple
3A	02-017	Oil Jar	18	02-006	Elbow
3B	02-027	Oiler Cap	19	02-044	Filter Cap and Filter Assy.
3C	02-032	Wick	19A	02-012	Cap
3D	02-159	Gasket (not shown)	19B	02-014	Filter
3E	02-222	Oiler Orifice	19C	02-016	Jar
4	02-143	Elbow	19D	02-033	Gasket (not shown)
5	02-165	Vacuum Filter Assy.	19E	02-185	Filter Frame
5A	02-158	Gasket (not Shown)	20	02-007	Nipple
5B	02-223	Filter Holder	21	02-045	Relief Cap and Relief Assy.
5C	02-010	Filter Cap	21A	01-576	Relief Cap Assy.
5D	02-023	Felt Filter (3 reqd.)	21B	02-074	Pipe Bushing (not shown)
5E	02-011	Vacuum Filter Jar	21C	02-013	Pressure Relief
6	01-513	Vacuum Tee Assy.	21D	02-033	Gasket (not shown)
7	01-075	Spring	21E	01-069	Jar (mod.)
8	01-563	Metering Screw Assy.	22	02-153	Hose Fitting

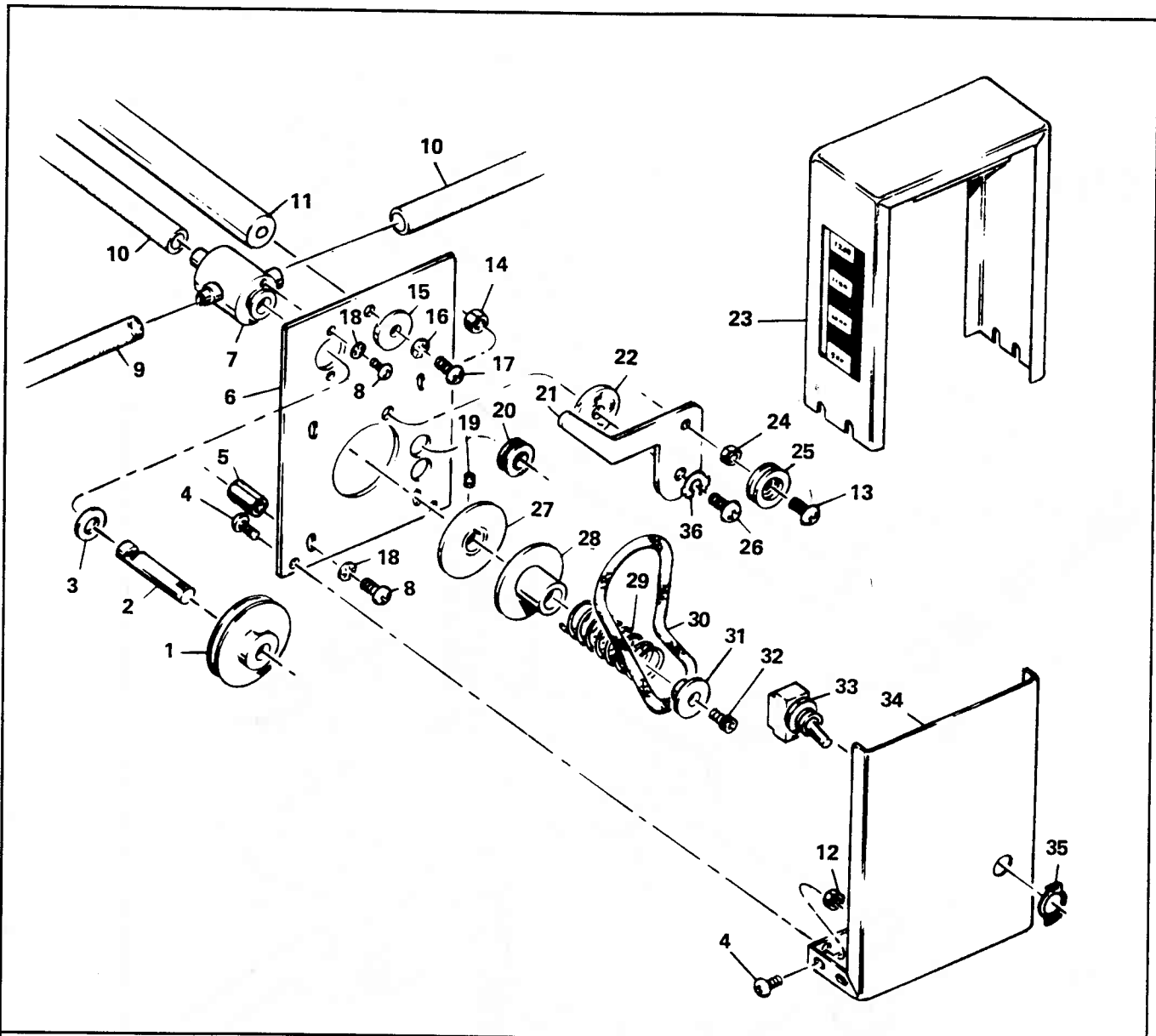

ITEM	PART NO.	DESCRIPTION	ITEM	PART NO.	DESCRIPTION
1	01-170	Valve Sheave	19	02-072	1/4-20 x 1/4 S.H.S.S.
2	*01-021	Valve Rotor	20	02-001	Grommet
3	01-097	Spacer	21	01-002	Idler Arm
4	02-061	#8-32 x 3/8 R.H.M.S.	22	01-182	Brake Washer
5	02-227	Spacer	23	01-510	Cover Assy.
6	01-003	Back Plate	24	02-109	#10-32 UNF Hex Nut
7	*01-517	Valve Body Assy.	25	01-508	Idler Roller Assy.
8	02-061	#8-32 x 3/8 R.H.M.S.	26	01-068	Idler Arm Bolt
9	01-044	Handpiece Hose	27	01-560	Sheave Face Assy. (inner)
10	01-045	Pressure Hose	28	01-559	Sheave Face Assy.
11	01-221	Handle	29	01-015	Spring
12	02-104	#8-32 Hex Nut	30	02-005	Belt
13	02-066	#10-32 x 1/2 R.H.M.S.	31	01-017	Spring Retainer
14	02-073	1/4-28 Hex Nut	32	02-067	#10-32 x 1/2 S.H.C.S.
15	01-047	Retainer	33	02-004	Switch
16	02-069	#10 Lock Washer	34	01-040	Switch Cover
17	02-105	#10-32 x 5/8 R.H.M.S.	35	02-003	Switch Plate
18	02-063	#8 Lock Washer	36	02-043	Retainer Ring

* Sold only as 01-537 Valve Kit.

01-501

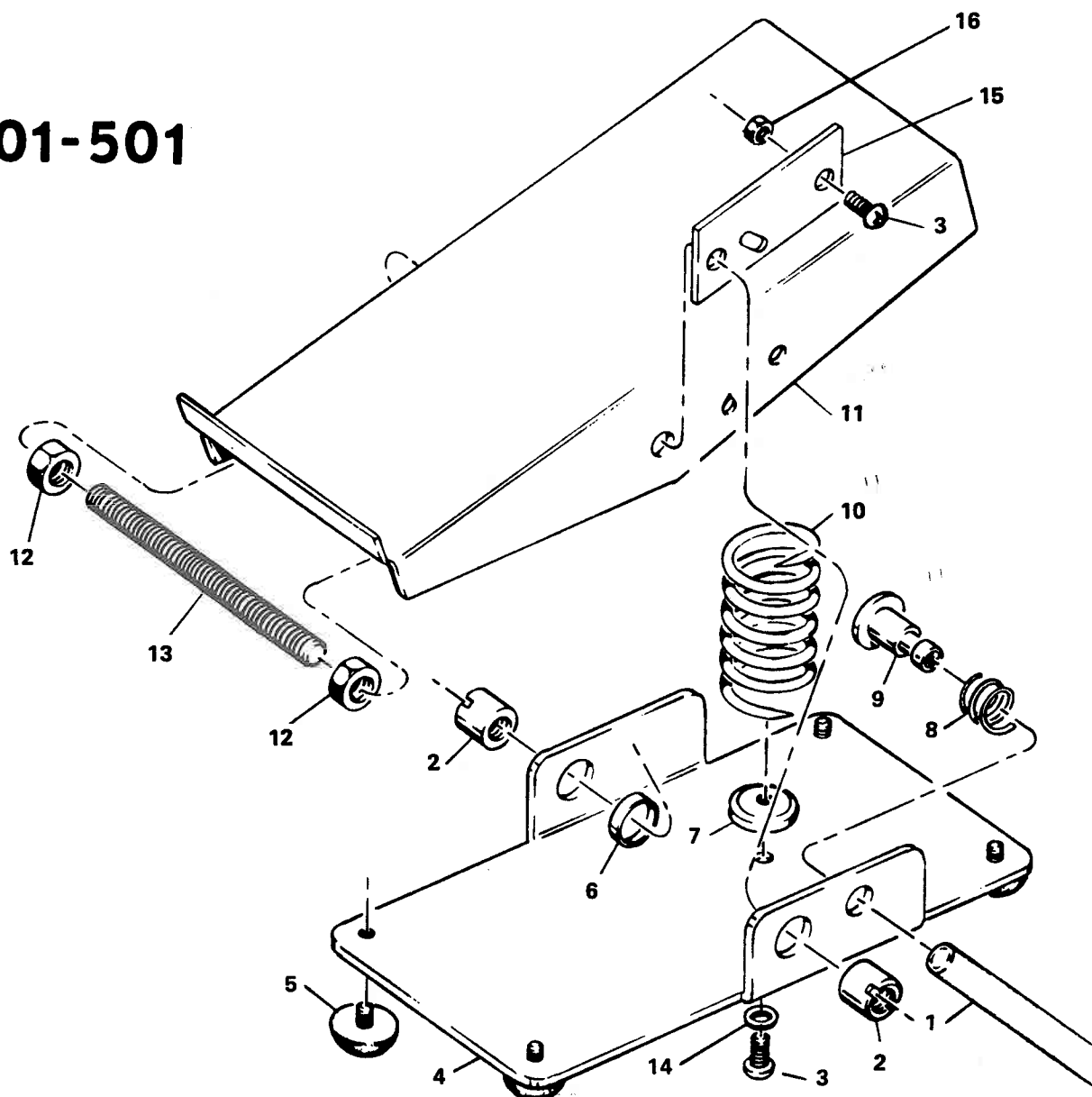

ITEM	PART NO.	DESCRIPTION
--	01-501	Throttle Assy.
1.	01-050	Throttle Hose
2.	01-028	Throttle Hinge Nut
3.	02-061	#8-32 x 3/8 R.H.M.S.
4.	01-019	Throttle Base Plate
5.	02-036	Rubber Foot
6.	01-053	Spacer
7.	02-526	Spring Retainer
8.	01-037	Outlet Spring
9.	01-026	Throttle Outlet
10.	01-036	Throttle Spring
11.	01-018	Hinge Plate
12.	02-073	1/4-28 Hex Nut
13.	01-035	Throttle Hinge Shaft
14.	02-063	#8 Lock Washer
15.	01-091	Valve Port
16.	02-104	8-32 UNC Hex Nut

GRS Corporation, P.O. Box 748, Emporia, KS 66801



SUBJECT: Gravermeister Performance Diagnosis

INTRODUCTION:

With a properly tuned Gravermeister, you should be able to cut 1/32" lettering with complete confidence and control, yet have power for the deepest cuts. New machines have a number of improvements and older machines can be updated with most of these components. Among these are: 1) New rotary valve that gives more power, a more crisp handpiece stroke, and longer life. 2) New throttle valve port system for improved throttle action. 3) New additions and improvements in handpieces. If you have a friend who has a new machine, you might ask to try it for comparison!

Following are some suggestions for checking and improving the performance of your machine.

POWER UNIT

Pump: These are rugged and rarely need service other than oiling. However, changing filters and gaskets every year or two is good practice. Flushing the pump is required only if the vanes stick. This sometimes happens when the unit is not used frequently. We recommend flushing your pump with a safety solvent such as 1,1,1-trichloroethane. This is available from GRS in a convenient aerosol can (part no. ~~02-237~~). Follow flushing instructions below:

Flushing Instructions: Remove both large aluminum jars from the machine. The vacuum filter is located about 4" from the oil jar. Remove the vacuum filter jar and unscrew the nylon filter holder which holds the felt filters in place. Turn the pump on and inject the flushing solvent into the 1/2" threaded hole exposed when you removed the nylon filter holder. You may want to tip the pump upward so that the solvent runs toward the back of the pump. Flushing is much easier if you use an aerosol solvent with a pliable nozzle extender tube such as GRS part no. 02-237. Let the pump run a few minutes to discharge the solvent. Repeat several times, if necessary. Make sure that the solvent is directed toward the rear of the pump or it will not reach the vanes. You will know that you have injected enough solvent when you observe solvent being expelled from the muffler. Once the pump is working normally, reassemble and test. If flushing does not correct sticking vanes, contact GRS for assistance.

NOTE: If sticking vanes and gummy deposits become a regular problem, we recommend you use Automatic Transmission Fluid (Dexron type for GM cars) instead of the normally recommended SAE 10 wt. detergent automotive oil in your pump oiler.

IMPORTANT: Do not forget to empty the muffler-filter jar every time you add oil to the oil jar!

OIL USAGE: A Gravermeister should use a jar of oil in about 10 to 25 hours of use. Oil consumption will vary with the on/off cycle time. A machine that is used continuously for several hours without turning it off will use more oil than a machine which is only on for occasional use. This is because the rate of oil use increases as the machine warms up. Oil usage increases with increased power levels. If you are doing heavy cutting, you will use a lot more oil than for light work.

Oil consumption can be adjusted by adjusting the wick in the oiler. If it uses too much, pull the wick out of the oiler body about 1/8" and observe results. If it still uses too much, try pulling it out further. Over oiling can cause gumming on the vanes, handpiece, and rotary valves. If it uses too little, push the wick in. If this does not solve the problem, a new wick should be installed. This wick is included in the pump service kit.

ROTARY VALVES: Worn rotary valves cause the greatest performance decrease. After several years, the valve may develop excessive clearance and should be replaced. This is especially true of machines built prior to 1978 which have the old valve design. The new valve and rotor design gives better performance and lasts longer.

New valves are checked at the factory for optimum performance. However, this is a check that cannot easily be performed without special equipment. You can check for excessive clearance and wear between the rotor and valve body in the following manner:

1. Unplug the machine. Remove the strokes/minute cover and then the belt. Now, check for excessive clearance between the rotor and valve by moving the valve pulley up and down. If there is noticeable "play", the valve is worn and performance may be decreased.
2. Remove the pulley and rotor assembly and examine rotor for wear--especially near the pulley end. Check the valve body bushing where it extends from the valve for evidence of wear. Excessive clearance can cut the performance to less than half what it should be. If in doubt, install a new valve kit.

REMEDY: A. Install new valve kit (p/n 01-537) which includes valve body, rotor, pressure and vacuum hoses, hose clamps, and instructions.

OR

- B. Contact GRS Corporation about rebuilding and updating your machine for you.
3. Earlier Gravermeisters were equipped with plastic pressure and vacuum hoses (milky-white in color) leading to the valve. These older hoses may leak at the connections and this should be corrected. Adding hose clamps will solve this leakage problem, but will not improve the condition caused by a worn valve. On later machines these hoses were changed to a heavy-duty type and equipped with hose clamps.

4. Some customers tell us that their valve rotor will sometimes accumulate a "gummy" residue and not turn freely. (A slipping belt would be a certain indication of this.) This may be due to excessive oil consumption, incorrect oil, or long periods of not using the machine. Remove the rotor periodically and clean with solvent; then, coat it with light machine oil. This practice should extend the life of the valve, belt, etc. If this condition seems chronic, try switching to automatic transmission fluid (Dexron type) for use in your pump oiler.

FOOT THROTTLE:

New throttles have an added valve port with improved valve action at the throttle inlet. Older throttles do not have this feature and are a bit more sensitive to throttle movement and wear. If the sliding valve surfaces are kept oiled, there is usually no problem, but when was the last time you oiled yours?

Most throttles we have rebuilt indicate they have never been oiled or oiled very infrequently.

Throttle problems occur when the valve does not close off completely at full throttle position or it does not operate smoothly throughout full movement. To check performance, give it full throttle and observe the stroke power of the handpiece. Then, completely pinch off the throttle hose. If the stroke power increases, the throttle is worn and leaking.

- REMEDY:
1. Purchase new throttle assembly (p/n 01-501).
 2. Send in your old throttle for rebuild and update.
 3. If it works satisfactorily, reward with a drop of oil frequently.

NOTE: A few older Gravermeisters had an in-line metal orifice installed inside the throttle hose just above the foot throttle. This orifice should be removed after replacing the old throttle with a new or updated throttle.

HANDPIECE:

Most common problem is caused by dirt or oil in the handpiece bore and piston. Clean with solvent. It is sometimes necessary to swab the bore with solvent to remove all the dirt or gummy oil. Be sure the bottom of the bore is clean.

Symptoms are sluggish and erratic power control. If you start down with the throttle and suddenly the strokes start at a stronger level than desired, this is the problem. You cannot do the fine cuts with confidence.

- REMEDY:
1. Thoroughly clean handpiece body, piston, and spring in a clean solvent which leaves no oily residue. Reassemble the handpiece without oiling.

2. Try a light coating of spray dry-lube on the piston or a small amount of dry graphite.

A worn foot throttle can also cause erratic or unpredictable handpiece operation. If there is evidence of wear or the sliding surfaces of the throttle valve do not operate smoothly, control can be unpredictable. (See throttle section.)

New handpieces are hard coated for an extremely hard wear surface. Older ones are anodized, but without the hard surface. Many engravers now prefer the mini handpiece or the new LT handpiece (even smaller) for finer work.

We have seen a few handpieces with enlarged bores through extensive use. This was evident by sluggish performance and excessive pressure leakage from the handpiece ports. (You can feel it and even hear it.)

You should use the best suited handpiece for each particular job. For finer work, our LT handpiece is ideal. Heavy material removal is best done with the large handpiece. Remember the mini handpiece is a good compromise between power and control. Like any compromise, you never get the best of either end of the spectrum. The LT and large handpieces are at opposite ends of this spectrum and well worth investigating for many particular applications.

HANDPIECE GETS HOT:

A few users tell us their handpiece gets uncomfortably warm. We are sometimes puzzled by this comment and feel that perhaps some users are especially sensitive to temperature. If this is a problem, try spiral wrapping the handpiece above the bleed holes with a layer of plastic or electrical tape. This will provide additional insulation -- or try a new mini or LT handpiece. These are now covered with a durable plastic -- full length -- which effectively insulates the handpiece.

NOTE: A possible source of excessive heat can occur if the pressure relief valve is not operating properly (or improperly set). Pressure is set at the factory for 9 p.s.i. If this is increased, excessive heat will be evident. This is an important item we check when we rebuild and update a Gravermeister and is a factory setting on all new machines.

HOSE LENGTH:

We have been asked about using longer handpiece hoses. Yes, you can try a longer hose, but here is what happens:

1. Power is reduced.
2. Stroke is less "crisp".

Because the principle of operation is alternating pressure and vacuum, a Gravermeister does work best with the shortest handpiece hose possible. Some tell us they use a longer hose with satisfactory results however. There is no harm in trying various hose lengths to see what works for you.

GRAVERS:

Some engravers tell us of two problems with gravers in the handpiece chuck:

1. Not tight enough.

SOLUTION: Use full throttle while tightening and loosening chuck nut. You should not need a pair of pliers or a spanner wrench.

2. Knife gravers, liners, etc. do not fit properly.

SOLUTION: Grind tang end of graver as shown below. Be sure to round the tang end so it does not damage jaw spring.

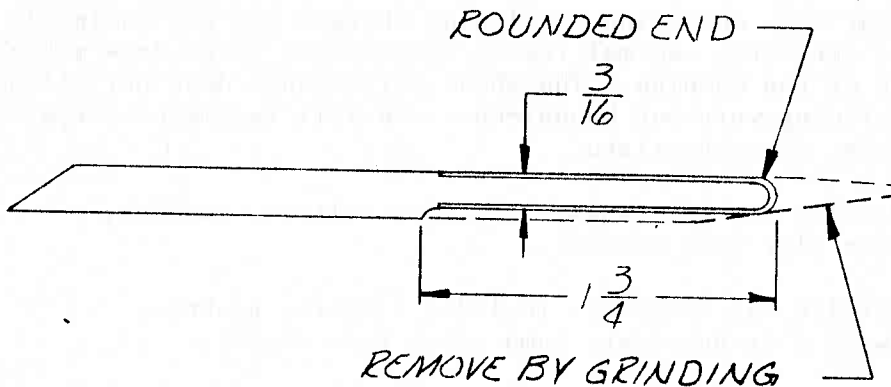

POINT BREAKAGE AND CARBIDE GRAVERS:

A few tell us of excessive graver point breakage. This can be due to several factors:

1. Operator technique. Be sure the tool is placed in position before starting the cut -- and be sure the graver does not "bounce" against the chip. Be careful making tight curves. Side pressure can snap the point.
2. Cutting harder metals. Point failure is more frequent. Try increasing face angle and try a more blunt belly (or heel) angle. A small radius on the bottom of the heel will help considerably.
3. Graver lube. Try a graver lube. We find that lubricating, penetrating oil works very well -- the kind for loosening rusty bolts. The lubricating variety works best. It comes in a spray can and a light coat sprayed directly on the piece helps. It is so thin that it does not create a heavy distracting coating either. Auto supply stores carry this product. We like a brand called TREMOR made by Beltraction Company. If you do not want to spray it on, just dip your graver occasionally on a pad soaked with the lube.

4. Carbide gravers. You might try one of these. Many have good results cutting hard metals they previously could not cut. They are, however, prone to breakage -- especially if you put the least bit of twist or side force on them. For best results, face angle must be increased and belly or heel must not have a sharp edge.

SERVICE AND PARTS YOU MAY NEED:

1. Gravermeister Rebuild and Update: This includes complete servicing of unit, new filter elements, gaskets, replacement of valve (if necessary), throttle update, etc. to new machine performance.

Labor and material often range between \$80 - \$100 plus, depending upon condition. Shipping charges are not included in this estimate. Normal return shipment is three days after receipt of the machine. The above price range does not allow for replacing worn out handpieces. We will recommend a new handpiece, if appropriate.

2. Pump Service Kit W/O Vanes: Includes filters, gaskets, and oiler wick (p/n 02-049).
3. Pump Service Kit W/Vanes: Includes filters, gaskets, oiler wick plus necessary pump vanes (p/n 02-026).
4. Safety Solvent: Aerosol can (p/n 02-237).
5. Valve Kit: Includes complete instructions (p/n 01-537).
6. New Throttle Assembly: (p/n 01-501).
7. Handpieces: Large (p/n 01-509)
Mini (p/n 01-536)
LT (p/n 01-527)
8. Two-Way Valve: For quickly switching between two handpieces.
9. Carbide Square Gravers: (p/n 02-233)
10. Gravermeister Parts/Operating Manual.
11. Reprint from ENGRAVERS JOURNAL Magazine. A 20-page series of five articles about the Gravermeister machine, some engraving techniques, tools, and other helpful information.

NOTE: PLEASE CONTACT GRS CORPORATION FOR CURRENT PRICE AND AVAILABILITY BEFORE ORDERING.